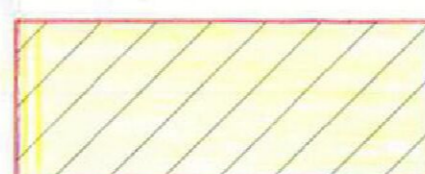

24 M. WIDE INTERNAL ROAD
13.41 M. WIDE REVENUE RASTA

50% Freezed Plots Shown Thus 

15% Mortgaged Plots Shown Thus 

NOTE:-

1. ALL DIMENSIONS ARE IN METERS.
2. NO PROJECTION /CANTILEVER ALLOWED IN THE REAR SETBACK.

LEGEND:- PROPOSED PLOTS FOR FLOORS (27 Nos.) 

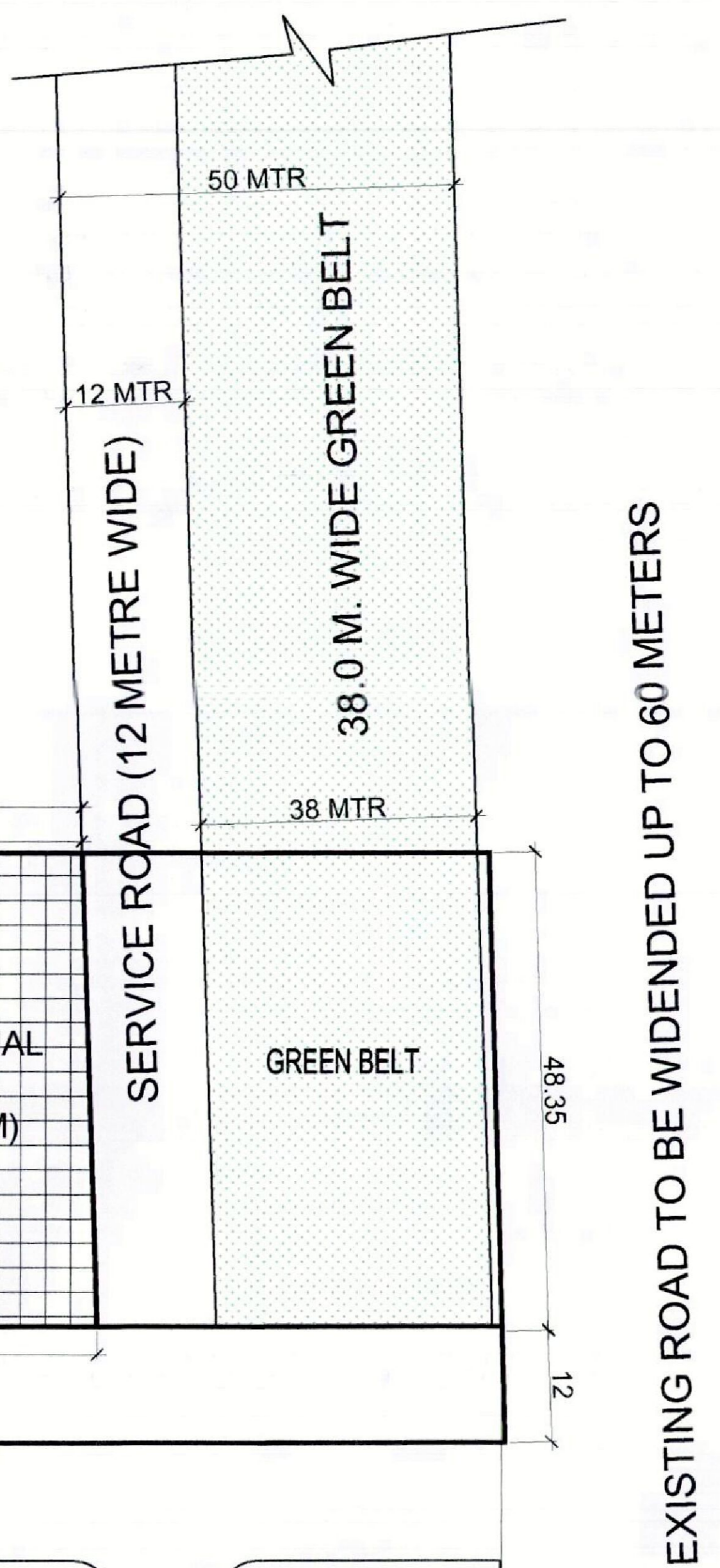
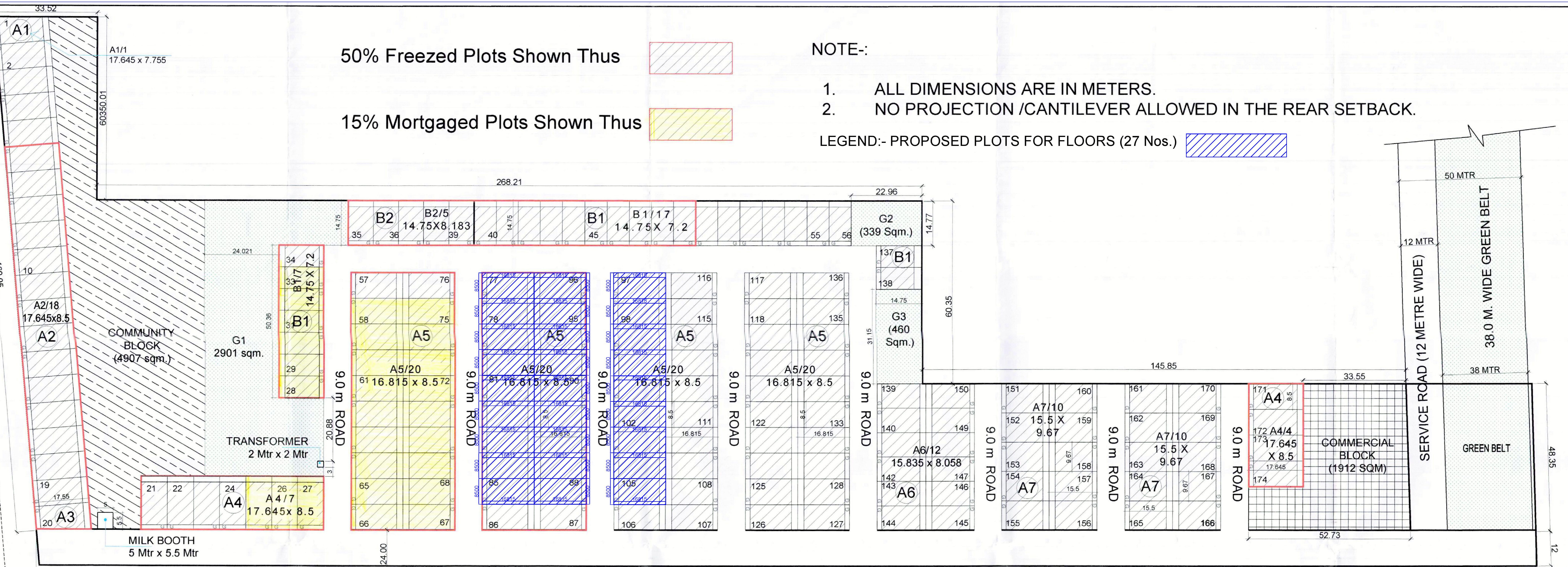

EXISTING ROAD TO BE WIDENED UP TO 60 METERS

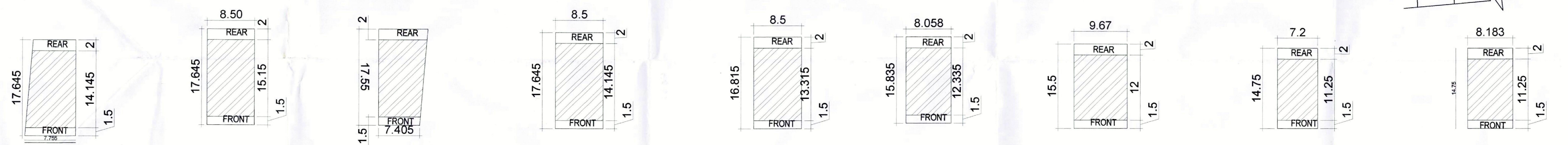

TYPE- A1	
PLOT NO.	1
DIMENSION	17.645M x 7.755M
AREA	136.837 SQ.M

TYPE- A2	
PLOT NO.	2 TO 19
DIMENSION	17.645 M x 8.5M
AREA	149.983 SQ.M

TYPE- A3	
PLOT NO.	20
DIMENSION	17.550M x 7.405M
AREA	129.958SQM

TYPE- A4	
PLOT NO.	21-27,171-174
DIMENSION	17.645M x 8.5M
AREA	149.983 SQ.M

TYPE- A5	
PLOT NO.	57-136
DIMENSION	16.815M x 8.5M
AREA	142.928 SQ.M

TYPE- A6	
PLOT NO.	139-150
DIMENSION	15.835M x 8.058M
AREA	127.598 SQ.M

TYPE- A7	
PLOT NO.	151-170
DIMENSION	15.500M x 9.670M
AREA	149.885 SQ.M

TYPE- B1	
PLOT NO.	28-34,40-56,137,138
DIMENSION	14.750M x 7.200M
AREA	106.200SQ.M

TYPE- B2	
PLOT NO.	35-39
DIMENSION	14.750M x 8.183M
AREA	120.699SQ.M

FORM-BRS-II

{See code 2.2(2)}

Certificate for structure conforming under Self-Certification

1. Plot No. 77,78,79, 80,81,82,83 ,84,85,88,89 ,90,91,92,93, 94,95, 96, 97,98,99
,100,101,102, 103,104,105, Trehan Valley, MKS County
Sector – 2, Sohna, Gurgaon, Haryana.

M/s Trehan Hospitality and Reality Pvt. Ltd. through its authorized signatory

It is hereby certified that the plans submitted in form BRS-I for the building detailed above are in conformity with Haryana building code-2017 and the approved zoning plan of the plot. The structure has been designed in accordance with the provision of national building code for structures resistance to earthquakes and other natural hazards. The local soil conditions, its load bearing capacity and the underground water table etc. have been kept in view while designing the same.

Dated:- 08/11/2024



Nisarg Trehan

Signature of the owner

Mobile No. : 9911226153

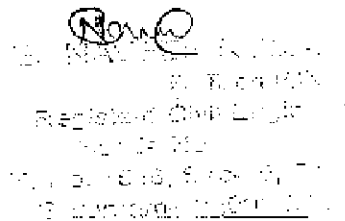

Dr. NAVEEN KUMAR
Registered Civil Engineer
Haryana
No. 8826791656

Dr. Naveen Kumar

Signature of the Engineer

Mobile No.:8826791656

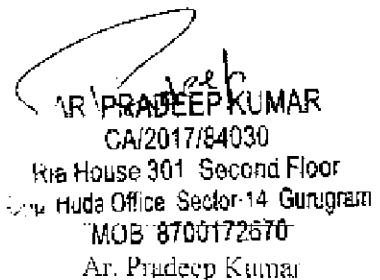

MR. PRADEEP KUMAR
CA/2017/84030
Ria House 301 Second Floor
Gur. Huda Office Sector-14 Gurugram
MOB 8700172670
Ar. Pradeep Kumar

Signature of the Architect

Mobile No.: 8700172670

AFFIDAVIT

I certified that

Ar. Pradeep Kumar, Ria House 301, Second Floor, Opp. Huda Office, Sector- 14, Gurugram, Haryana.

1. Is the architect of Plot No.- 77,78,79, 80,81,82,83 ,84,85,88,89 ,90,91,92,93, 94,95, 96, 97,98,99 ,100,101,102, 103,104,105 Trehan Valley, Mks County, Sohna, Sector- 2, Gurugram, Haryana.
2. That this plot is constructing under my supervision & according to Haryana Building code-2017. This is approved by D.G.T.C.P.
That the building plan is as per zoning & demarcation plan shall not deviate from its provisions.
3. That I visited and found that all functionally like (road, sewer, water and electricity) are workable at site.

AR PRADEEP KUMAR
CA/2017/84030
Ria House 301 Second Floor
Opp Huda Office Sector-14 Gurugram
MOB 8700172670

ARCHITECT'S SIGNATURE

Verification:-

Verified that the contents of my above affidavit are true and correct to the best of my knowledge and belief and nothing has been concealed therein.

AR PRADEEP KUMAR
CA/2017/84030
Ria House 301 Second Floor
Opp Huda Office Sector-14 Gurugram
ARCHITECT'S SIGNATURE
MOB 8700172670

AFFIDAVIT

I do hereby solemnly affirm and declares:-

1. That we are owner of Plot No. 77,78,79, 80,81,82,83 ,84,85,88,89 ,90,91,92,93, 94,95, 96, 97,98,99 ,100,101,102, 103,104,105 .
2. That the plot measuring 142.93 Sq. Mtrs. each in the license colony known as MKS County, Sohna, Sector- 2, Gurugram, Haryana.



Deponent

Verification:-

Verified that the contents of our above affidavit are true and correct to the best of our knowledge and belief and nothing has been concealed therein.



Deponent

AR PRADEEP KUMAR
CA 2017/84030
Ria House 301 Second Floor
Opp Huda Office Sector-14 Gurugram
Signature: 8700472678
MOB: 8700472678

VERIFICATION

Applied for Building Plan Approval Vide Application Dated 26-09-2024 on for BRS-I for Plot No. 77,78,79, 80,81,82,83 ,84,85,88,89 ,90,91,92,93, 94,95, 96, 97,98,99 ,100,101,102, 103,104,105 Trehan Valley, MKS CountySector – 2, Sohna, Gurgaon, Haryana hereby verify and affirm that contents of this affidavit are true and correct verify and that the contents of this affidavit are true and correct to the best of our knowledge, belief and information in witness whereof I have signed hereunder on _____

Place: Gurgaon

Dated: 08-11-2024



Deponent

SITE REPORT

1. I have visited the site of Plot No. 78, MKS County, Sector - 2, Sohna, Gurgaon, Haryana.
For the purpose of building plans approval, to verify the current status of the above said plot, my observation regarding the plot is under.
2. The site of Plot No. 78, MKS County, Sector - 2, Sohna, Gurgaon, Haryana is vacant.
3. The adjoining plot no. - East - Plot No. 95 MKS County, Sector - 2, Sohna, Gurgaon, Haryana
4. The adjoining Plot no. - West - 9.0 m wide road.
5. The adjoining Plot no. - North - Plot No. 77 MKS County, Sector - 2, Sohna, Gurgaon, Haryana
6. The adjoining Plot no. - South - Plot No. 79 MKS County, Sector - 2, Sohna, Gurgaon, Haryana

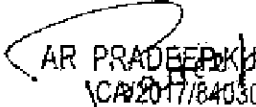

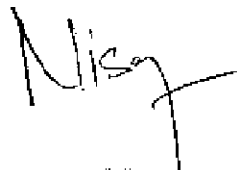
AR PRADEEP KUMAR
ICA/2017/84030
Ria House 301 Second Floor
Opp. Huda Office Sector-14 Gurugram
Signature of Lic. Architect
MOB: 8700772870

Signature of Owner

SITE REPORT

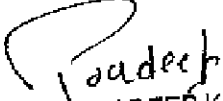
1. I have visited the site of Plot No. 79, MKS County, Sector - 2, Sohna, Gurgaon, Haryana.
For the purpose of building plans approval, to verify the current status of the above said plot, my observation regarding the plot is under.
2. The site of Plot No. 79, MKS County, Sector - 2, Sohna, Gurgaon, Haryana is vacant.
3. The adjoining plot no. - East - Plot No. 94 MKS County, Sector - 2, Sohna, Gurgaon, Haryana
4. The adjoining Plot no. - West - 9.0 m wide road.
5. The adjoining Plot no. - North - Plot No. 78 MKS County, Sector - 2, Sohna, Gurgaon, Haryana
6. The adjoining Plot no. - South - Plot No. 80 MKS County, Sector - 2, Sohna, Gurgaon, Haryana

AR PRADEEP KUMAR
CA/2017/84030
Ria House 301 Second Floor
Opp. PNB Office Sector 14 Gurgaon
MOB 8700172670

Signature of Owner

SITE REPORT

1. I have visited the site of **Plot No. 80, MKS County, Sector – 2, Sohna, Gurgaon, Haryana.**

For the purpose of building plans approval, to verify the current status of the above said plot, my observation regarding the plot is under.

2. The site of **Plot No. 80, MKS County, Sector – 2, Sohna, Gurgaon, Haryana** is vacant.
3. The adjoining plot no. – **East - Plot No. 93 MKS County, Sector – 2, Sohna, Gurgaon, Haryana**
4. The adjoining Plot no. – **West – 9.0 m wide road.**
5. The adjoining Plot no. – **North - Plot No. 79 MKS County, Sector – 2, Sohna, Gurgaon, Haryana**
The adjoining Plot no. – **South - Plot No. 81 MKS County, Sector – 2, Sohna, Gurgaon, Haryana**



Signature of the Architect
AR PRADEEP KUMAR

CA/2017/84030

Ria House 301 Second Floor

Opp. nua's Office Sector-14 Gurgaon

MOB 8700172670

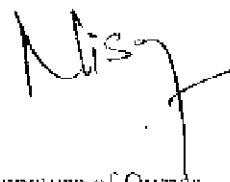

Signature of Owner

S117 31/03/11

1. I have visited the site of Plot No. 81, MKS County, Sector - 2, Sohna, Gurgaon, Haryana.
For the purpose of final plan approval, to verify the current status of the above said plot - subject of this application (Plot No. 81).
2. The location of Plot No. 81, MKS County, Sector - 2, Sohna, Gurgaon, Haryana is -

The adjoining plot no. - East - Plot No. 92 MKS County, Sector - 2, Sohna, Gurgaon, Haryana.
The adjoining plot no. - West - Plot No. 80 MKS County, Sector - 2, Sohna, Gurgaon, Haryana.

The adjoining plot no. - North - Plot No. 80 MKS County, Sector - 2, Sohna, Gurgaon, Haryana.

The adjoining plot no. - South - Plot No. 82 MKS County, Sector - 2, Sohna, Gurgaon, Haryana.

[Handwritten Signature]
Name of the Applicant
Address of the Applicant
City - Gurgaon, Haryana
Pin Code - 122001, India
Date of the Application

[Handwritten Signature]
Name of the Applicant

SITE REPORT

1. I have visited the site of Plot No. 82, MKS County, Sector - 2, Sohna, Gurgaon, Haryana.

For the purpose of building plans approval, to verify the current status of the above said plot, my observation regarding the plot is under.

2. The site of Plot No. 82 MKS County, Sector - 2, Sohna, Gurgaon, Haryana is vacant.
3. The adjoining plot no. - East - Plot No. 91 MKS County, Sector - 2, Sohna, Gurgaon, Haryana
4. The adjoining Plot no. - West - 9.0 m wide road.
5. The adjoining Plot no. - North - Plot No. 81 MKS County, Sector - 2, Sohna, Gurgaon, Haryana
6. The adjoining Plot no. - South - Plot No. 83 MKS County, Sector - 2, Sohna, Gurgaon, Haryana



AR PRADEEP KUMAR
CA/2017/84030
Ria House 301 Second Floor
Signature of Sector Office Gurgaon
Opp. Huda Office Sector 21 Gurgaon
MOB 8700172670

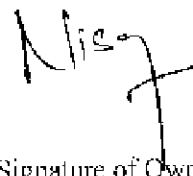

Signature of Owner

NOTE RECORD

1. I have visited the site of **Plot No. 83, MKS County, Sector - 2, Sohna, Gurgaon, Haryana.**

For the purpose of bonding pass approval to verify the current status of the above said plot, my observation regarding the plot is as follows:

2. The site of **Plot No. 83, MKS County, Sector - 2, Sohna, Gurgaon, Haryana** is vacant.

The adjoining plot no. - East - Plot No. 80 MKS County, Sector - 2, Sohna, Gurgaon, Haryana.

3. The adjoining Plot no. - West - 90 m wide road.

3. The adjoining Plot no. - North - Plot No. 82 MKS County, Sector - 2, Sohna, Gurgaon, Haryana.

4. The adjoining Plot no. - South - Plot No. 84 MKS County, Sector - 2, Sohna, Gurgaon, Haryana.

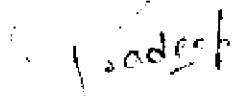
P. SADEESH KUMAR
08220284033
Superior PCC Dept. of PWD
Sector - 2, Plot No. 83, Gurgaon
Haryana - 122002

Signature of Owner

1. The first part of the document is a list of the names of the members of the committee.

2. The second part of the document is a list of the names of the members of the committee.

3. The third part of the document is a list of the names of the members of the committee.

4. The fourth part of the document is a list of the names of the members of the committee.

5. The fifth part of the document is a list of the names of the members of the committee.

6. The sixth part of the document is a list of the names of the members of the committee.

7. The seventh part of the document is a list of the names of the members of the committee.

8. The eighth part of the document is a list of the names of the members of the committee.

9. The ninth part of the document is a list of the names of the members of the committee.

SITE REPORT

1. I have visited the site of Plot No. 85, MKS County, Sector - 2, Sohna, Gurgaon, Haryana.
For the purpose of building plans approval, to verify the current status of the above said plot, my observation regarding the plot is under.
2. The site of Plot No. 85, MKS County, Sector - 2, Sohna, Gurgaon, Haryana is vacant.
3. The adjoining plot no. - East - Plot No. 88 MKS County, Sector - 2, Sohna, Gurgaon, Haryana
4. The adjoining Plot no. - West - 9.0 m wide road.
5. The adjoining Plot no. - North - Plot No. 84 MKS County, Sector - 2, Sohna, Gurgaon, Haryana
6. The adjoining Plot no. - South - Plot No. 86 MKS County, Sector - 2, Sohna, Gurgaon, Haryana

AR/PRADEEP KUMAR
CA/2017/84080
Ria House 301, Second Floor,
Opp. Huda Office Sector 14, Gurgaon
Signature: 07007311001

Signature of Owner

SITE REPORT

1. I have visited the site of Plot No. 88, MKS County, Sector - 2, Sohna, Gurgaon, Haryana.
For the purpose of building plans approval, to verify the current status of the above said plot, my observation regarding the plot is under.
2. The site of Plot No. 88, MKS County, Sector - 2, Sohna, Gurgaon, Haryana is vacant.
3. The adjoining plot no. - East - 9.0 m wide road
4. The adjoining Plot no. - West - Plot No. 85 MKS County, Sector - 2, Sohna, Gurgaon, Haryana
5. The adjoining Plot no. - North - Plot No. 89 MKS County, Sector - 2, Sohna, Gurgaon, Haryana
6. The adjoining Plot no. - South - Plot No. 87 MKS County, Sector - 2, Sohna, Gurgaon, Haryana



AR PRADEEP KUMAR

CA/2017/84033

Ria House 301, Sector 14, Gurgaon

Signature Office, Sector 14, Gurgaon

MOB: 9700172379



Signature of Owner

SITE REPORT

1. I have visited the site of **Plot No. 89, MKS County, Sector – 2, Sohna, Gurgaon, Haryana.**
For the purpose of building plans approval, to verify the current status of the above said plot, my observation regarding the plot is under.
2. The site of **Plot No. 89, MKS County, Sector – 2, Sohna, Gurgaon, Haryana** is vacant.
3. The adjoining plot no. – **East – 9.0 m wide road.**
4. The adjoining Plot no. – **West - Plot No. 84 MKS County, Sector – 2, Sohna, Gurgaon, Haryana**
5. The adjoining Plot no. – **North - Plot No. 90 MKS County, Sector – 2, Sohna, Gurgaon, Haryana**
6. The adjoining Plot no. – **South - Plot No. 88 MKS County, Sector – 2, Sohna, Gurgaon, Haryana**

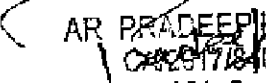

AR PRADEEP KUMAR
CIN 291724030
Ria House 301 Second Floor
Opp Huda Office Sector-14 Gurugram
MOB 8700172670

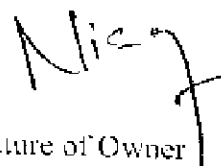
Signature of the Architect

Signature of Owner

SITE REPORT

1. I have visited the site of **Plot No. 90, MKS County, Sector - 2, Sohna, Gurgaon, Haryana.**
For the purpose of building plans approval, to verify the current status of the above said plot, my observation regarding the plot is under.
2. The site of **Plot No. 90, MKS County, Sector - 2, Sohna, Gurgaon, Haryana** is vacant.
3. The adjoining plot no. -- **East** - 9.0 m wide road.
4. The adjoining Plot no. - **West** - Plot No. 83 MKS County, Sector - 2, Sohna, Gurgaon, Haryana
5. The adjoining Plot no. - **North** - Plot No. 91 MKS County, Sector - 2, Sohna, Gurgaon, Haryana
6. The adjoining Plot no. - **South** - Plot No. 89 MKS County, Sector - 2, Sohna, Gurgaon, Haryana

AR PRADEEP KUMAR
CA/2017/184033
Ria House 301 Second Floor
Huda Office, Sector-14, Gurgaon
MOB 8703172015

Signature of Owner

SITE REPORT

1. I have visited the site of **Plot No. 91, MKS County, Sector – 2, Sohna, Gurgaon, Haryana.**
For the purpose of building plans approval, to verify the current status of the above said plot, my observation regarding the plot is under.
2. The site of **Plot No. 91, MKS County, Sector – 2, Sohna, Gurgaon, Haryana** is vacant.
3. The adjoining plot no. – **East** - 9.0 m wide road.
4. The adjoining Plot no. – **West** - Plot No. 82 MKS County, Sector – 2, Sohna, Gurgaon, Haryana
5. The adjoining Plot no. – **North** - Plot No. 92 MKS County, Sector – 2, Sohna, Gurgaon, Haryana
6. The adjoining Plot no. – **South** - Plot No. 90 MKS County, Sector – 2, Sohna, Gurgaon, Haryana

AR. PRADEEP KUMAR
CA/2017/84030
Ris House 301 Second Floor
Opp Huda Office Sector-14 Gurugram
Signature MOE (8794178670)

Signature of Owner

SITE REPORT

1. I have visited the site of **Plot No. 92, MKS County, Sector - 2, Sohna, Gurgaon, Haryana.**
For the purpose of building plans approval. to verify the current status of the above said plot, my observation regarding the plot is under.
2. The site of **Plot No. 92, MKS County, Sector - 2, Sohna, Gurgaon, Haryana** is vacant.
3. The adjoining plot no. - **East - 9.0 m wide road.**
4. The adjoining Plot no. - **West - Plot No. 81 MKS County, Sector - 2, Sohna, Gurgaon, Haryana**
5. The adjoining Plot no. - **North - Plot No. 93 MKS County, Sector - 2, Sohna, Gurgaon, Haryana**
6. The adjoining Plot no. - **South - Plot No. 91 MKS County, Sector - 2, Sohna, Gurgaon, Haryana**



AR PRADEEP KUMAR
CA/2017/84030
Ria House 301 Second Floor
Huda Office Sector-14 Gurugram
Signature of the Architect
8700172670

Signature of Owner

SITE REPORT

1. I have visited the site of **Plot No. 94, MKS County, Sector – 2, Sohna, Gurgaon, Haryana.**
For the purpose of building plans approval, to verify the current status of the above said plot, my observation regarding the plot is under.
2. The site of **Plot No. 94, MKS County, Sector – 2, Sohna, Gurgaon, Haryana** is vacant.
3. The adjoining plot no. – **East** – 9.0 m wide road.
4. The adjoining Plot no. – **West** - Plot No. 79 MKS County, Sector - 2, Sohna, Gurgaon, Haryana
5. The adjoining Plot no. – **North** - Plot No. 95 MKS County, Sector -- 2, Sohna, Gurgaon, Haryana
6. The adjoining Plot no. – **South** - Plot No. 93 MKS County, Sector – 2, Sohna, Gurgaon, Haryana

ARIPBADAR KUMAR
CA/2017/84030
Flr House 301 Second Floor
Huda Office Sector-14 Gurugram
Signature MOB: 8700172570

Signature of Owner

SITE REPORT

1. I have visited the site of **Plot No. 95, MKS County, Sector - 2, Sohna, Gurgaon, Haryana.**
For the purpose of building plans approval, to verify the current status of the above said plot, my observation regarding the plot is under.
2. The site of **Plot No. 95, MKS County, Sector - 2, Sohna, Gurgaon, Haryana** is vacant.
3. The adjoining plot no. - **East** - 9.0 m wide road.
4. The adjoining Plot no. - **West** - Plot No. 78 MKS County, Sector - 2, Sohna, Gurgaon, Haryana
5. The adjoining Plot no. - **North** - Plot No. 96 MKS County, Sector - 2, Sohna, Gurgaon, Haryana
6. The adjoining Plot no. - **South** - Plot No. 94 MKS County, Sector - 2, Sohna, Gurgaon, Haryana

AR **Pradeep Kumar**
CA/2017/84030
Flat House 301 Second Floor
Huda Office Sector 14 Gurugram
MOB 8780172670
Signature of the Architect

Signature of Owner

SITE REPORT

1. I have visited the site of **Plot No. 96, MKS County, Sector – 2, Sohna, Gurgaon, Haryana.**
For the purpose of building plans approval, to verify the current status of the above said plot, my observation regarding the plot is under.
2. The site of **Plot No. 96, MKS County, Sector – 2, Sohna, Gurgaon, Haryana** is vacant.
3. The adjoining plot no. – **East – 9.0 m wide road.**
4. The adjoining Plot no. – **West - Plot No. 77 MKS County, Sector – 2, Sohna, Gurgaon, Haryana**
5. The adjoining Plot no. – **North – 9.0 m wide road.**
6. The adjoining Plot no. – **South - Plot No. 95 MKS County, Sector – 2, Sohna, Gurgaon, Haryana**



AR PRADEEP KUMAR

CA/2017/84030

Signature of the Auditor
Ria House, Second Floor
Opp Huda Office Sector-14 Gurgaon

MOB 8700172670



Signature of Owner

SITE REPORT

1. I have visited the site of **Plot No. 97, MKS County, Sector - 2, Sohna, Gurgaon, Haryana.**
For the purpose of building plans approval, to verify the current status of the above said plot, my observation regarding the plot is under
2. The site of **Plot No. 97, MKS County, Sector - 2, Sohna, Gurgaon, Haryana** is vacant.
3. The adjoining plot no. - **East - Plot No. 116 MKS County, Sector - 2, Sohna, Gurgaon, Haryana**
4. The adjoining Plot no. - **West - 9.0 m wide road**
5. The adjoining Plot no. - **North - 9.0 m wide road.**
6. The adjoining Plot no. - **South - Plot No. 98 MKS County, Sector - 2, Sohna, Gurgaon, Haryana**

ANIL KUMAR
12/11/2020
Executive Engineer, Planning
Department, District, Gurgaon
Haryana
Signature of the Architect

Signature of Owner

SITE REPORT

1. I have visited the site of **Plot No. 99, MKS County, Sector – 2, Sohna, Gurgaon, Haryana.**
For the purpose of building plans approval, to verify the current status of the above said plot, my observation regarding the plot is under.
2. The site of **Plot No. 99, MKS County, Sector – 2, Sohna, Gurgaon, Haryana** is vacant.
3. The adjoining plot no. – **East** - Plot No. 114 MKS County, Sector – 2, Sohna, Gurgaon, Haryana
4. The adjoining Plot no. – **West** – 9.0 m wide road.
5. The adjoining Plot no. – **North** - Plot No. 98 MKS County, Sector – 2, Sohna, Gurgaon, Haryana
6. The adjoining Plot no. – **South** - Plot No. 100 MKS County, Sector – 2, Sohna, Gurgaon, Haryana

Pradeep

Mr. PRADEEP KUMAR
CAJ2017184030
Signature of the Architect
Office: Sector 14, Gurugram
MOB: 8700172870

Nig

Signature of Owner

SITE REPORT

1. I have visited the site of Plot No. 100, MGS Colony, Sector - 2, Sohna, Gurgaon, Haryana.

In the course of bearing plans approval, to verify the current status of the above said plot, my observation regarding the plot is under:

2. The site of Plot No. 100, MGS Colony, Sector - 2, Sohna, Gurgaon, Haryana is vacant.

The adjacent plots are - East - Plot No. 101 MGS Colony, Sector - 2, Sohna, Gurgaon, Haryana.

- The adjoining Plot no. - West - 9 feet wide road.

3. The adjoining Plot no. - North - Plot No. 99 MGS Colony, Sector - 2, Sohna, Gurgaon, Haryana.

The adjoining Plot no. - South - Plot No. 102 MGS Colony, Sector - 2, Sohna, Gurgaon, Haryana.

S. Pradeep
ANIL KUMAR
CIVIL ENGINEER
REGISTERED PROFESSIONAL
ENGINEER
No. 100, MGS Colony, Sector - 2, Sohna, Gurgaon, Haryana.

M. K. J.
Signature of Officer

SEE REPORT

1. The site is situated at Plot No. 101, MKS Colony, Sector - 2, Sohna, Gurgaon, Haryana.
For the purpose of building plans approval, to verify the current status of the above said plot, my observation regarding the plot is under.
2. The site of Plot No. 101, MKS Colony, Sector - 2, Sohna, Gurgaon, Haryana is -
a) The adjoining plot no. - East - Plot No. 112 MKS Colony, Sector - 2, Sohna, Gurgaon, Haryana.
b) The adjoining Plot no. - West - Plot no. side road.
c) The adjoining plot no. - North - Plot no. side road, Plot no. side road, Plot no. side road, Plot no. side road.
d) The adjoining Plot no. - South - Plot no. side road, MKS Colony, Sector - 2, Sohna, Gurgaon, Haryana.

C. S. Sood
AR REGISTERED ARCHITECT
C/111, Sector 2, Sohna, Gurgaon
Haryana
NO. 37071

Abey
Signature of Owner

SITE REPORT

1. I have visited the site of **Plot No. 102, MKS County, Sector - 2, Sohna, Gurgaon, Haryana.**
For the purpose of building plans approval, to verify the current status of the above said plot, my observation regarding the plot is under.
2. The site of **Plot No. 102, MKS County, Sector - 2, Sohna, Gurgaon, Haryana** is vacant.
3. The adjoining plot no. - **East** - Plot No. 111 MKS County, Sector - 2, Sohna, Gurgaon, Haryana
4. The adjoining Plot no. - **West** - 9.0 m wide road.
5. The adjoining Plot no. - **North** - Plot No. 101 MKS County, Sector - 2, Sohna, Gurgaon, Haryana
6. The adjoining Plot no. - **South** - Plot No. 103 MKS County, Sector - 2, Sohna, Gurgaon, Haryana

MR PRADEEP KUMAR
CA/2017/84030
Signature of the Architect
House 301 Second Floor
14 Gurgaon
Office - 14 Gurgaon
8700172670

Signature of Owner

SITE REPORT

1. I have visited the site of **Plot No. 104, MKS County, Sector – 2, Sohna, Gurgaon, Haryana.**
For the purpose of building plans approval, to verify the current status of the above said plot, my observation regarding the plot is under.
2. The site of **Plot No. 104, MKS County, Sector – 2, Sohna, Gurgaon, Haryana** is vacant,
3. The adjoining plot no. - **East** - Plot No. 109 MKS County, Sector – 2, Sohna, Gurgaon, Haryana
4. The adjoining Plot no. - **West** - 9.0 m wide road.
5. The adjoining Plot no. - **North** - Plot No. 103 MKS County, Sector – 2, Sohna, Gurgaon, Haryana
6. The adjoining Plot no. - **South** - Plot No. 105 MKS County, Sector - 2, Sohna, Gurgaon, Haryana

AR **Pradeep KUMAR**
CA/2017/24030
Ria House 301 Second Floor
Opp Huda Office Sector 14 Gurgaon
MOB: 8760172670
Signature of the Architect

Signature of Owner

SITE REPORT

1. I have visited the site of Plot No. 105, MKS County, Sector – 2, Sohna, Gurgaon, Haryana.
For the purpose of building plans approval, to verify the current status of the above said plot, my observation regarding the plot is under.
2. The site of Plot No. 105, MKS County, Sector – 2, Sohna, Gurgaon, Haryana is vacant.
3. The adjoining plot no. – East - Plot No. 108 MKS County, Sector -- 2, Sohna, Gurgaon, Haryana
4. The adjoining Plot no. – West – 9.0 m wide road.
5. The adjoining Plot no. – North - Plot No. 104 MKS County, Sector – 2, Sohna, Gurgaon, Haryana
6. The adjoining Plot no. – South - Plot No. 106 MKS County, Sector – 2, Sohna, Gurgaon, Haryana

Pradeep

MR PRADEEP KUMAR
CA/2017/24030
Via House 301 Second Floor
Signature Office Sector 14 Gurgaon
MOB 8700172670

Misra

Signature of Owner