

AREA CALCULATION FOR SITE UNDER 500 TO 800 Mtr. TOD ZONE = 17.41 ACS.(A)	
A = 128.39 x 64.73/2	= 4155.33 Sqm.
B = (146.03 + 206.19)/2 x 60.14	= 10591.25 Sqm.
C = 206.19 x 6.91	= 1424.77 Sqm.
D = (212.92 + 236.37)/2 x 24.11	= 5416.19 Sqm.
E = 236.37 x 109.99	= 25998.34 Sqm.
F = (229.66 + 176.02)/2 x 50.29	= 10200.82 Sqm.
G = 176.02 x 16.76	= 2950.10 Sqm.
H = 164.28 x 67.05	= 11014.97 Sqm.
J = 33.55 x 41.92 / 2	= 703.21 Sqm.
TOTAL	= 72454.98 - 1983.15 = 70471.83 Sqm. (17.41 ACS.)

AREA CALCULATION FOR SITE UNDER 0 TO 500 Mtr. TOD ZONE = 0.49 ACS.(B)	
R = 79.29 x 39.63/2	= 1571.13 Sqm.
S = 28.00 x 29.43/2	= 412.02 Sqm.
TOTAL	= 1983.15 Sqm. (0.49 ACS.)

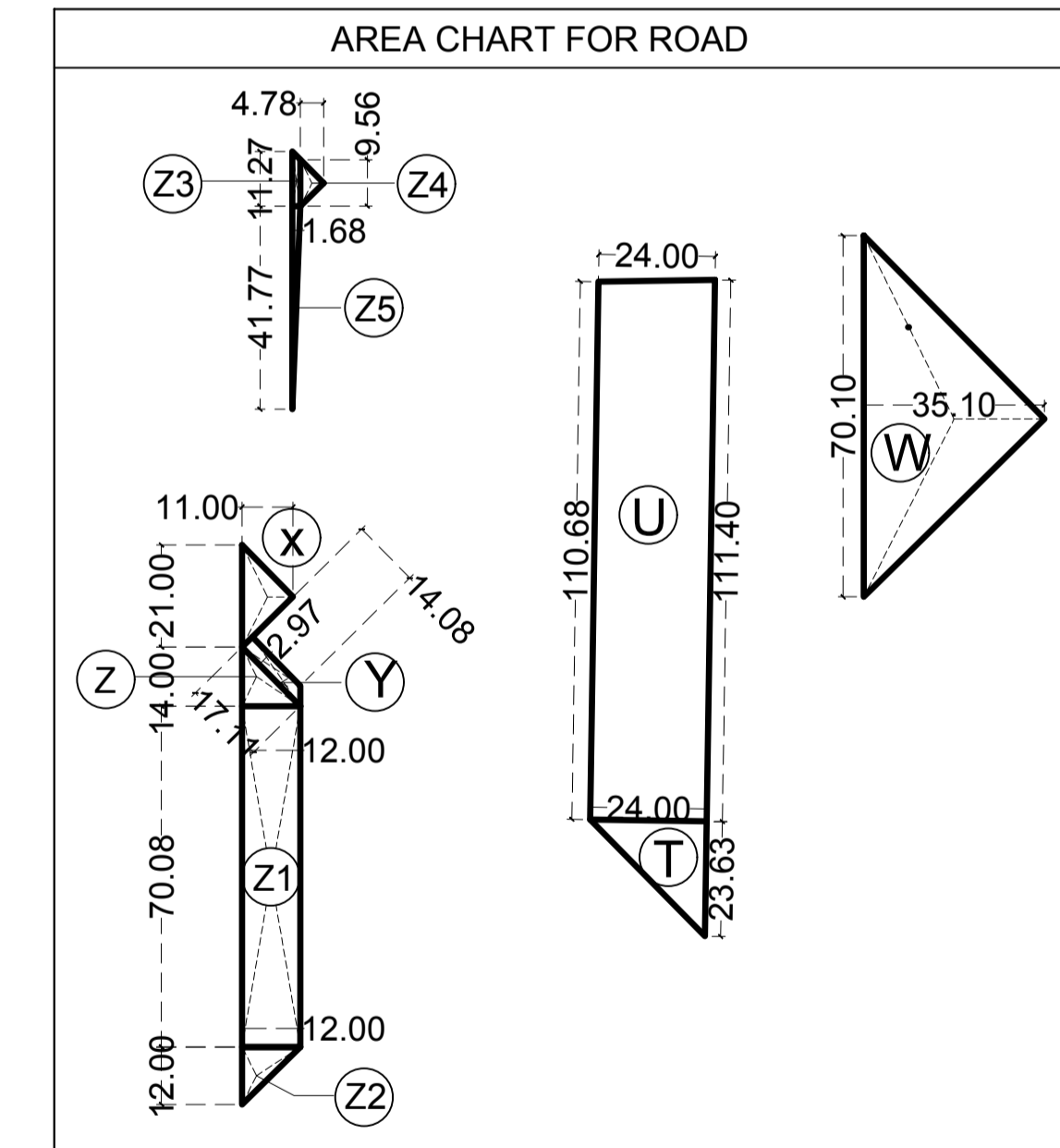
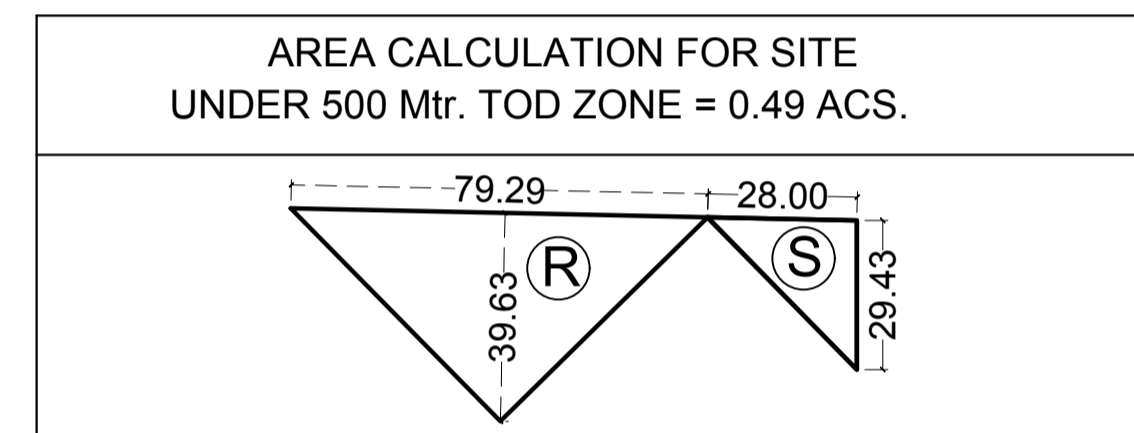

AREA CALCULATION FOR SERVICE ROAD 12.0 M. WIDE	
X = 11.00 x 21.00 / 2	= 115.50 Sqm.
Y = (17.11 + 14.08)/2 x 2.97	= 46.32 Sqm.
Z = 12.00 x 14.00 / 2	= 84.00 Sqm.
Z1 = 12.00 x 70.08	= 840.96 Sqm.
Z2 = 12.00 x 12.00 / 2	= 72.00 Sqm.
Z3 = (11.27 + 9.56)/2 x 1.68	= 17.50 Sqm.
Z4 = 9.56 x 4.78 / 2	= 22.85 Sqm.
Z5 = 1.68 x 41.77 / 2	= 35.09 Sqm.
TOTAL	= 1234.22 Sqm.

AREA CALCULATION FOR SECTOR ROAD 60 M. WIDE	
w = 70.10 x 35.10 / 2	= 1230.25 Sqm.
TOTAL	= 1230.25 Sqm.

AREA CALCULATION FOR SECTOR ROAD 24.0 M. WIDE	
T = 24.00 x 23.00 / 2	= 276.00 Sqm.
U = 110.68 + 111.40/2 x 24.00	= 2664.96 Sqm.
TOTAL	= 2940.96 Sqm.

TOTAL ROAD AREA = (1234.22+1230.25+2940.96)	= 5405.43 Sqm.	= 1.34 ACS.
(AREA CALCULATION FOR SITE UNDER 500 TO 800 MTR. TOD ZONE)	(TOTAL ROAD AREA)	
= (70471.83)	= (5405.43)	
= 65066.40 Sqm.		
= 16.07 ACS.		

Total Site Area (17.41 + 0.49) = 17.90acs. (A+B)
 Area Under 60.00 Mt. Wide Sector Road = 1230.25 Sqm
 Area Under 24.00 Mt. Wide Road = 2940.96 Sqm.
 Area Under 12.00 Mt. Wide Service Road = 1234.22 Sqm.
 (NET PLANNED AREA) - (TOTAL ROAD AREA)
 = (72454.98 - 5405.43)
 = 67049.55 Sqm.
 = (17.90 ACS. - 1.34 ACS.)
 = 16.56 ACS.

AUTHORIZED SIGNATORY

ARCHITECT

PROJECT:
 DEMARCATION PLAN OF RESIDENTIAL GROUP HOUSING COLONY UNDER TRANSIT ORIENTED DEVELOPMENT ON AN AREA MEASURING 17.90 ACS. IN SECTOR- 102 GURUGRAM.

CLINT:
 EVENTUAL BUILDERS PVT. LTD. IN COLLABORATION WITH SARASWATI INFRASTRUCTURE PVT.LTD. M-11, MIDDLE CIRCLE, CONNAUGHT CIRCUS, NEW DELHI-11.