

DEMARICATION PLAN OF PLOTTED COLONY UNDER DEEN DAYAL JAN AAWAS
YOJNA ON THE LAND MEASURING 22.35625 ACRES
AT VILLAGE-WAZIRPUR, SECTOR-95, TEHSIL HARSRU, DISTT-GURUGRAM.
FOR M/S : JMS INFRA REALTY PRIVATE LIMITED

DEMARICATION PLAN

- UNDER GROUND WATER TANK
- UNDER GROUND STP TANK
- COMMERCIAL
- GREEN/PARK
- COMMUNITY SERVICES
- TRANSFORMER
- AREA UNDER ROAD

DP
ATP
JD
JC
PAT

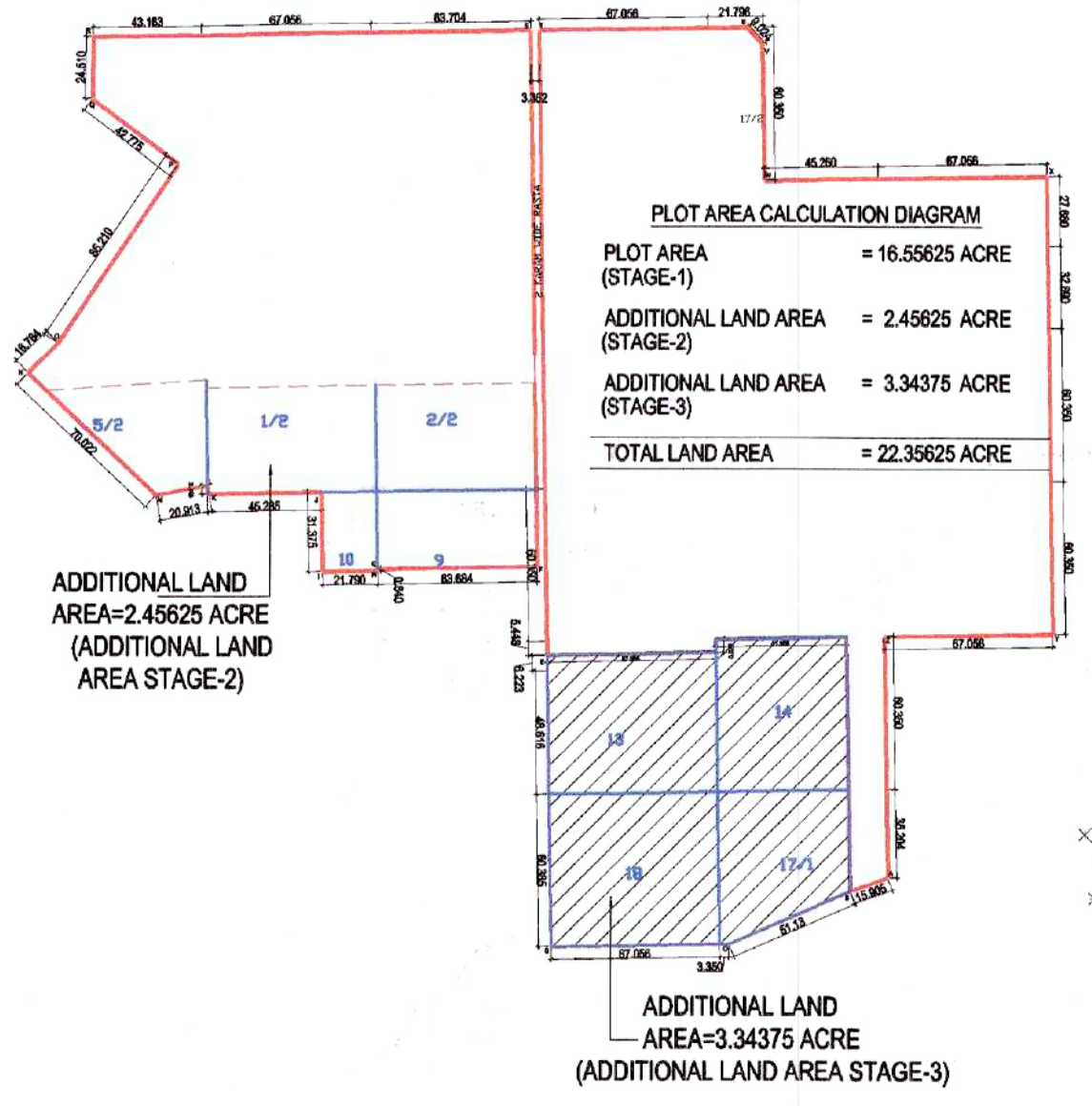

AREA STATEMENT

DESCRIPTION	REQUIRED AREA		PROPOSED AREA	
	ACRES	SQ.MT.	ACRES	SQ.MT.
A OLD PLOT AREA STAGE-1	16.55625	67000.767		
B ADDITIONAL PLOT AREA STAGE-2 (2.45625 ACRES)	2.45625	9940.091		
C ADDITIONAL PLOT AREA STAGE-3 (3.34375 ACRES)	3.34375	13531.676		
TOTAL GROSS PLOT AREA (A + B + C)	22.35625	90472.534		
1 GROSS PLOT AREA	22.35625	90472.534		
2 NET PLOT AREA FOR PLANNING	22.35625	90472.534		
3 OPEN SPACE AREA (GREEN)	1.6767	6785.440	7.50%	1.68
4 AREA TO BE TRANSFERRED FREE OF COST TO THE GOVERNMENT (COMMUNITY)	2.2356	9047.253	10.00%	2.24
5 COMMERCIAL AREA	0.8943	3618.901	4.00%	0.85
6 SALEABLE AREA				11.50
7 TOTAL SALEABLE AREA (5) + (6)				12.35
8 TOTAL NO. OF PLOTS				396
9 MINIMUM PERMISSIBLE DENSITY @ 240 PPA				5366
10 MAXIMUM PERMISSIBLE DENSITY @ 400 PPA				8943

S.NO.	PLOT TYPE	SIZE OF PLOT (WIDTH X LENGTH) (MTRS)	PLOT AREA (SQ.MT.)	NO. OF PLOTS	TOTAL AREA (SQ.MT.)
1	1-8	16.15 x 24.35, 62.65, 147.15, 154.15, 146.17, 179.10, 210.11, 221.27, 240.27, 281.25, 151.18	100.750	140	13011.750
2	9-17	7.77 x 117.17, 122.13, 134.19, 135.14, 151.18	123.375	75	9940.125
3	18-21	9.00 x 18.50, 20.54, 20.54, 20.54	145.952	7	1021.664
4	22	35.42	124.500	7	871.500
5	23	7.08 x 20.62	146.300	1	146.300
6	24	7.08 x 20.70	146.700	1	146.700
7	25	7.08 x 20.71	147.000	1	147.000
8	26	7.08 x 20.76	147.381	1	147.381
9	27	6.51 x 15.50	101.250	1	101.250
10	28	7.51 x 15.50	116.400	2	232.800
11	29	9.62 x 15.50	149.110	1	149.110
12	30	6.80 x 15.50	106.300	1	106.300
13	31	IRREGULAR	146.456	1	146.456
14	32	45.54 x 7.31	332.851	10	3328.510
15	33	IRREGULAR	144.711	1	144.711
16	34	IRREGULAR	110.312	1	110.312
17	35	8.46 x 12.47	106.596	1	106.596
18	36	IRREGULAR	106.847	1	106.847
19	37	9.42 x 15.50	146.050	1	146.050
20	38	IRREGULAR	110.011	1	110.011
21	39	10.18 x 14.75	149.993	1	149.993
22	40	8.50 x 14.75	125.375	1	125.375
23	41	6.50 x 14.75	102.825	1	102.825
24	42	6.50 x 14.75	102.825	1	102.825
25	43	6.90 x 14.75	101.925	1	101.925
26	44	IRREGULAR	148.171	1	148.171
27	45	8.79 x 14.75	128.712	1	128.712
28	46	IRREGULAR	117.495	1	117.495
29	47	8.20 x 15.50	127.131	1	127.131
30	48	8.11 x 15.50	125.721	1	125.721
31	49	8.11 x 15.50	125.721	1	125.721
32	50	8.20 x 15.50	127.131	1	127.131
33	51	IRREGULAR	71.688	1	71.688
34	52	6.83 x 15.50	105.377	1	105.377
35	53	9.62 x 15.50	149.600	1	149.600
36	54	151.207 x 8.427	1282.222	18	23080.000
37	55	9.12 x 15.412	140.800	2	281.600
38	56	200.207 x 9.005	1803.578	2	3607.156
39	57	IRREGULAR	102.868	1	102.868
40	58	IRREGULAR	107.027	1	107.027
41	59	IRREGULAR	102.824	1	102.824
42	60	IRREGULAR	106.978	1	106.978
43	61	IRREGULAR	100.208	1	100.208
44	62	IRREGULAR	145.832	1	145.832
45	63	IRREGULAR	178.509	1	178.509
46	64	IRREGULAR	97.950	1	97.950
47	65	IRREGULAR	96.012	1	96.012
48	66	IRREGULAR	95.250	1	95.250
49	67	IRREGULAR	95.579	1	95.579
50	68	IRREGULAR	94.237	1	94.237
51	69	IRREGULAR	93.565	1	93.565
52	70	IRREGULAR	96.354	1	96.354
53	71	IRREGULAR	97.708	1	97.708

DETAIL OF PLOTS IN EXISTING LICENSED COLONY 19.0125 ACRES / LICENSE NO.11 OF 2022 DATED 02.02.2022 AND LICENSE NO-4 OF 2023 DATED 06.01.2023

DESCRIPTION	NUMBER OF PLOTS	POPULATION IN PERSON
ALREADY APPROVED PLOTS	321	5778 PERSON @ 18 PERSON PER PLOT
ADDITIONAL PLOTS ADDED IN REVISION WHILE GRANT OF LOI FOR 3.34375 ACRES	29	391.5 PERSON @ 13.5 PERSON PER PLOT
TOTAL	350	6169.50 PERSONS
DETAILS OF PLOTS IN ADDITIONAL APPLIED AREA 3.34375 ACRES		
NEW PLOT	46	621 PERSON @ 13.5 PERSON PER PLOT
DETAILS OF WHOLE COLONY 22.35625 ACRES (ALREADY LICENSED AREA (19.0125 ACRES) + APPLIED AREA (3.34375 ACRES))		
GRAND TOTAL	396	6790.50 PERSONS (DENSITY IN PPA=303.74 PPA)

GREEN AREA CALCULATION

S.NO.	WIDTH	LENGTH	AREA (SQ.MT.)
Green-1	AS PER PLINE		1200.609
Green-2	AS PER PLINE		101.608
Green-3	AS PER PLINE		225.631
Green-4	AS PER PLINE		70.919
Green-5	AS PER PLINE		71.989
Green-6	AS PER PLINE		71.955
Green-7	AS PER PLINE		129.702
Green-8	AS PER PLINE		184.220
Green-9	AS PER PLINE		884.771
Green-10	AS PER PLINE		163.058
Green-11	AS PER PLINE		19.486
Green-12	AS PER PLINE		125.449
Green-13	AS PER PLINE		51.538
Green-14	AS PER PLINE		268.604
Green-15	AS PER PLINE		116.299
Green-16	AS PER PLINE		588.651
Green-17	AS PER PLINE		161.410
Green-18	AS PER PLINE		565.112
Green-19	AS PER PLINE		15.901
Green-20	AS PER PLINE		98.648
Green-21	AS PER PLINE		450.200
Green-22	AS PER PLINE		1010.944
Green-23	AS PER PLINE		63.621
Green-24	AS PER PLINE		145.712
TOTAL AREA			6786.037

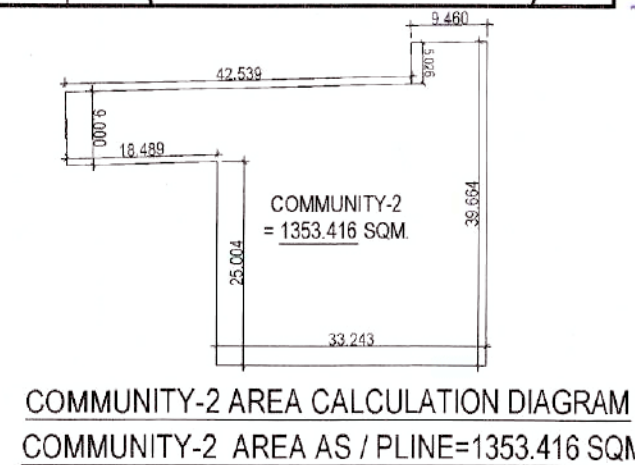

TOTAL COMMUNITY AREA CALCULATION

DESCRIPTION	AREA (SQ.MT.)
COMMUNITY-1 AREA AS / PLINE	7694.649
COMMUNITY-2 AREA AS / PLINE	1353.416
TOTAL COMMUNITY AREA AS / PLINE	9048.065

ADDITIONAL LAND AREA=3.34375 ACRE (ADDITIONAL LAND AREA STAGE-3)

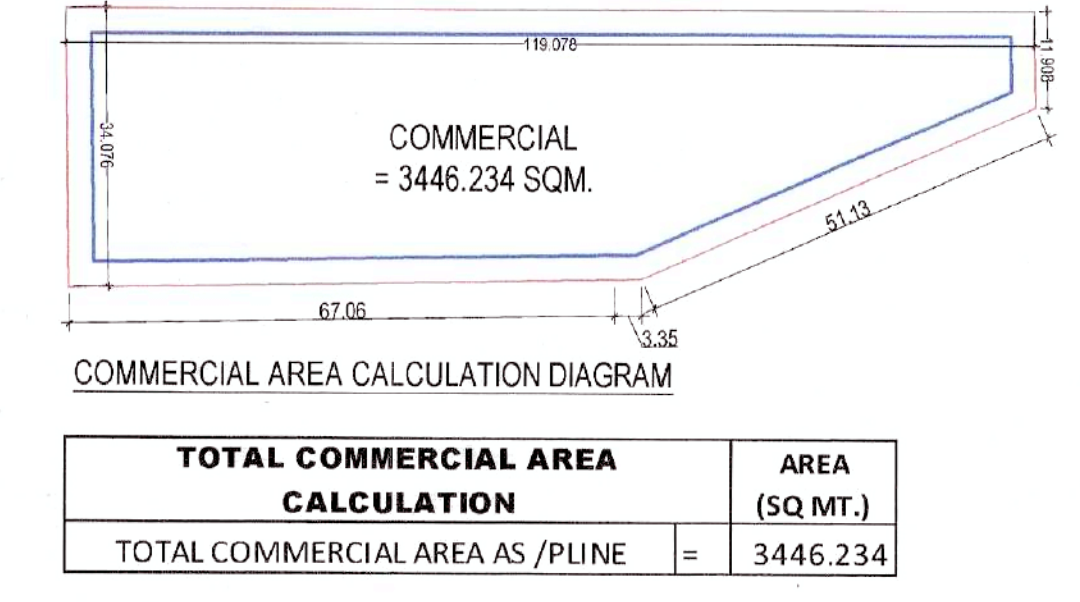
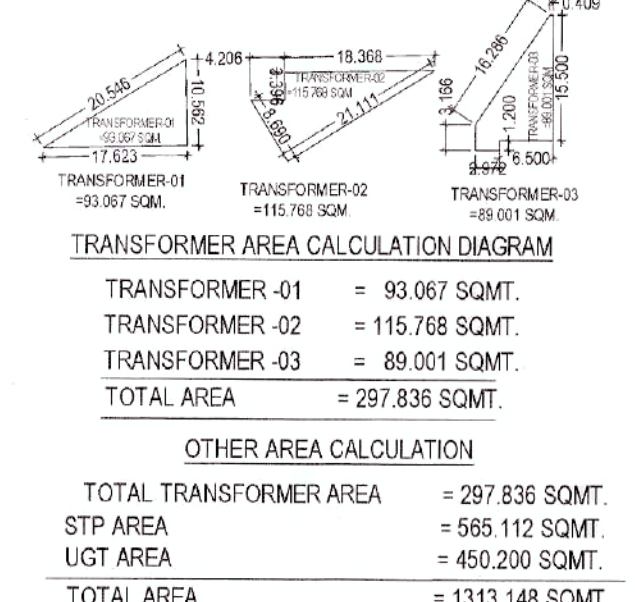
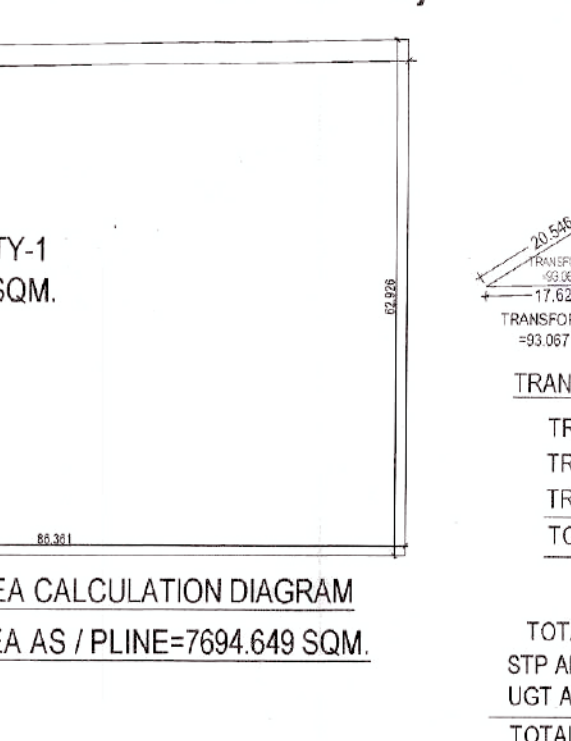

AREA UNDER 24 M WIDE ROAD

NAME	SHAPE	PLOT SIZES		AREA (SQ.MTRS.)	TOTAL AREA
		WIDTH	LENGTH		
1	TRIANGLE	17.078	23.480	200.496	200.50
2	RECTANGLE	23.480	53.168	1248.385	1248.38
3	TRIANGLE	23.480	20.358	239.003	239.00
4	RECTANGLE	(24.371 + 24.780)/2	261.524 + 259.588)/2	285.131	285.13
5	TRIANGLE	17.637	17.391	153.363	153.36
TOTAL				2126.38	

PROJECT:
 DEMARICATION LAYOUT PLAN OF PLOTTED COLONY UNDER DEEN DAYAL JAN AAWAS YOJNA ON THE LAND MEASURING 22.35625 ACRES AT VILLAGE-WAZIRPUR, SECTOR-95, TEHSIL HARSRU, DISTT-GURUGRAM, FOR M/S : JMS INFRA REALTY PRIVATE LIMITED

DRAWING TITLE:
 DEMARICATION LAYOUT PLAN DS-01

Architects:
DEEPAK MEHTA & ASSOCIATES
 ARCHITECTS, PLANNERS, VALUERS, LANDSCAPE & INTERIORS
 #11 2ND FLOOR, PLOT NO. 4, HANDEL PALLA L.L.C. AVAR ROAD PH-4, DEER-110008, INDIA
 TEL: 011-22772180, 91-9999219713, E-MAIL: deepakmehta@deemta.com, mehta@deemta.com, www.deemtaarchitect.co.in

SIG. OF ARCHITECT

SIG. OF OWNER