

(NARENDER KUMAR) (HITESH SHARMA) (P.P. SINGH) (AMIT KHATRI, IAS)
 (DTP(HQ)) (CTP(M)) (CTP(HR)) (DTP(HR))
 (SANJAY SAINI) (DINESH KUMAR) (DINESH KUMAR)
 (DTP(ATP(HQ))) (PA(HQ)) (PA(HQ))

Reg No DTCP 10162-XXXI Dated 01-04-2024

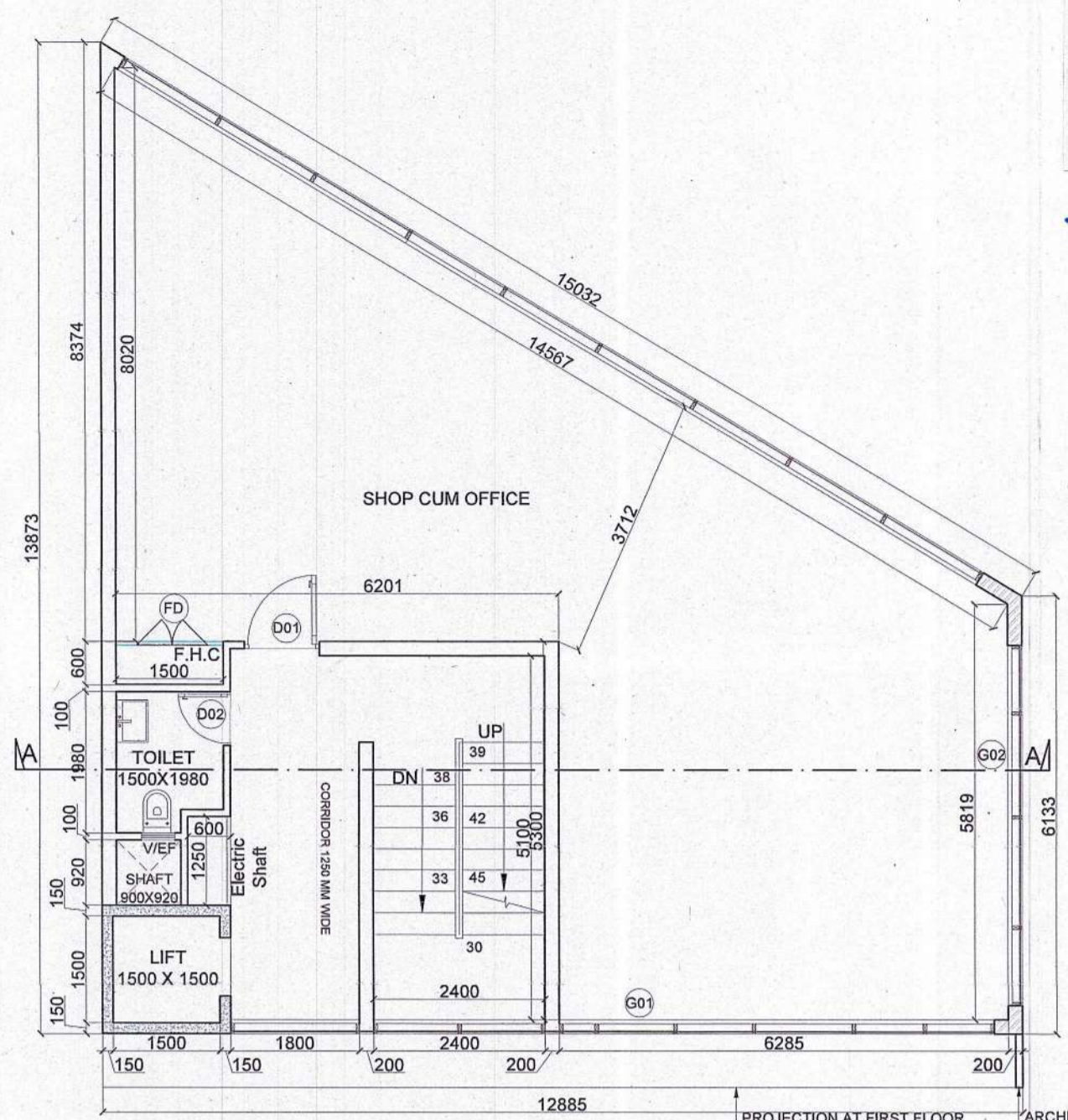
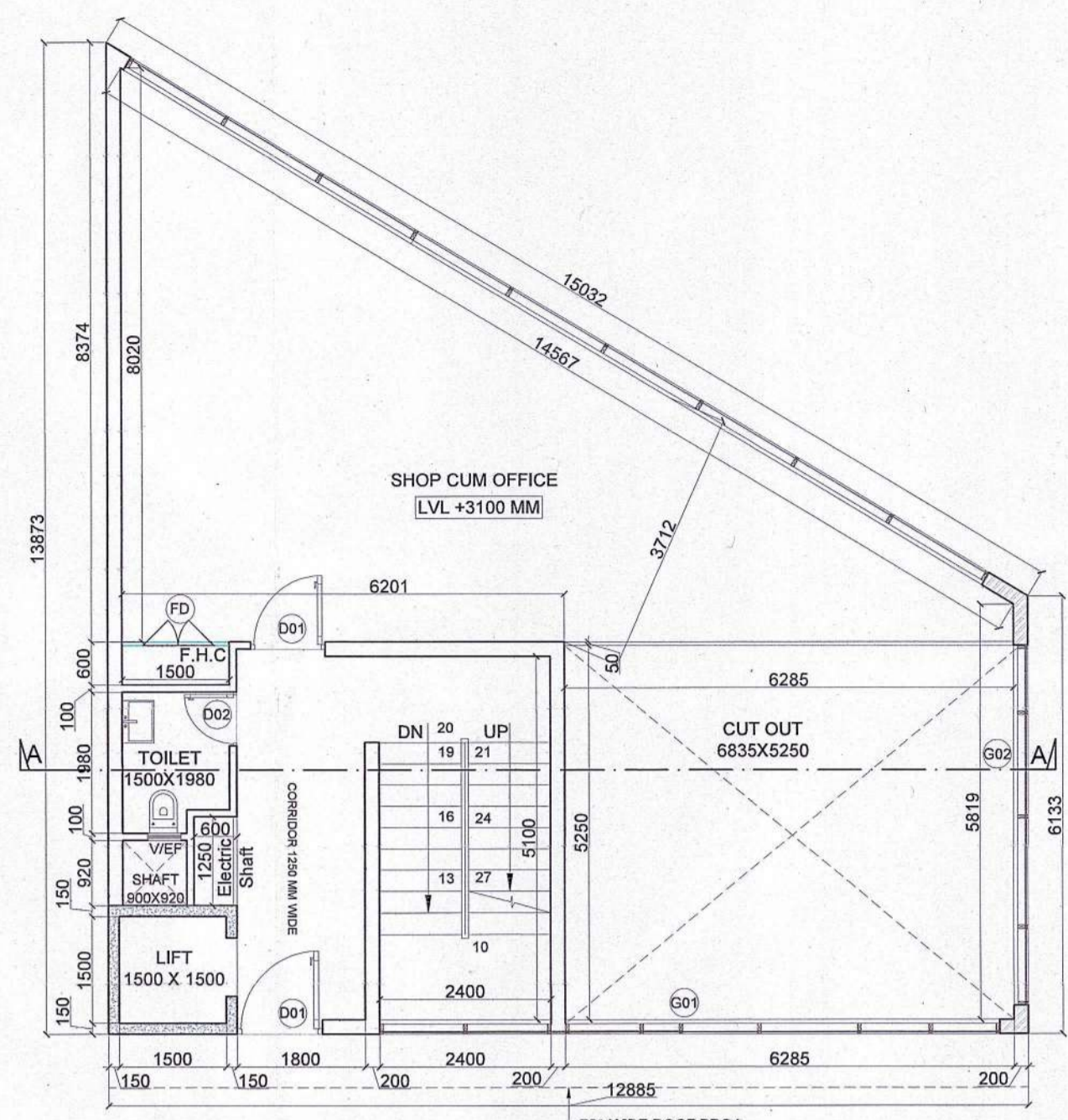
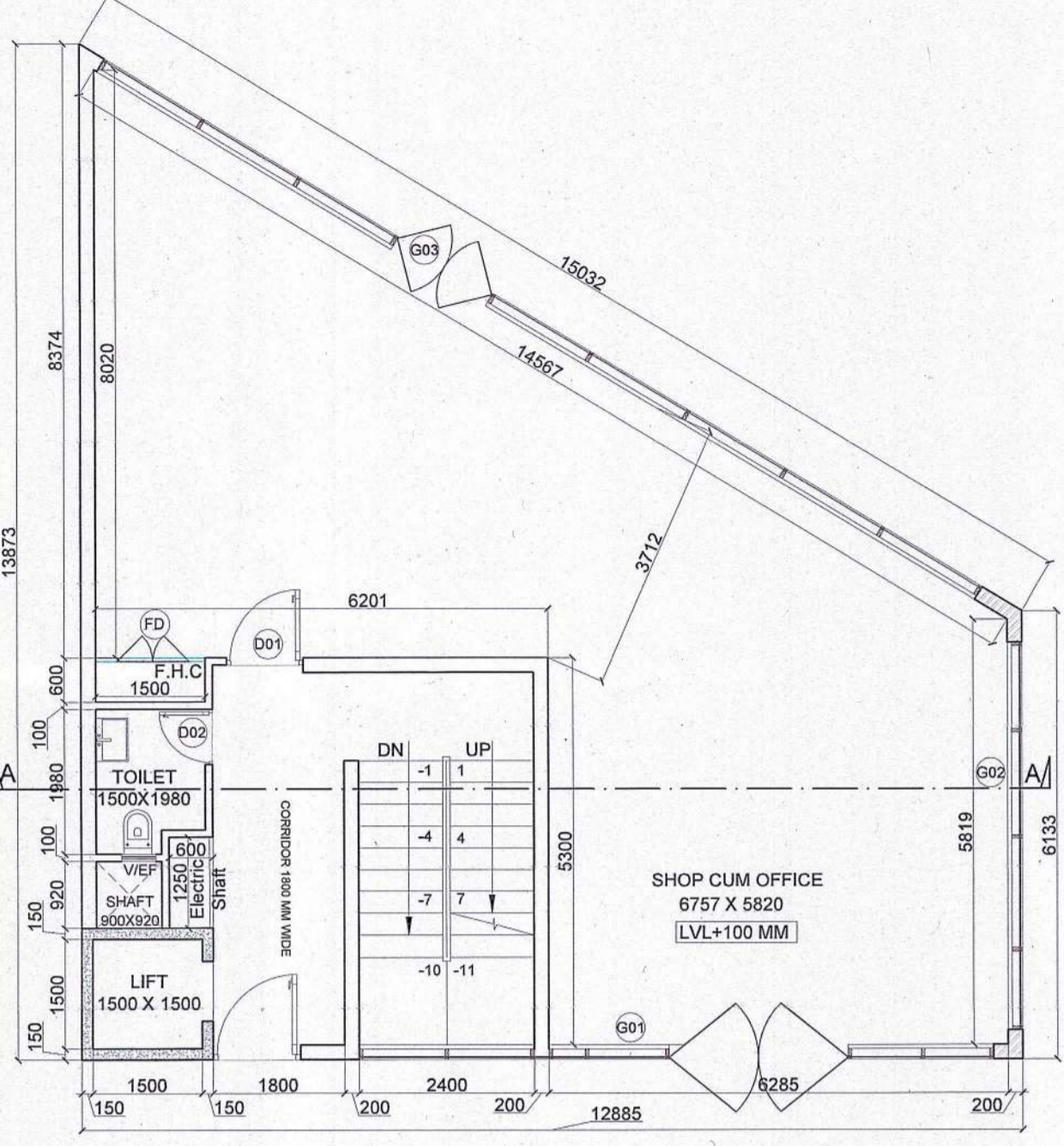
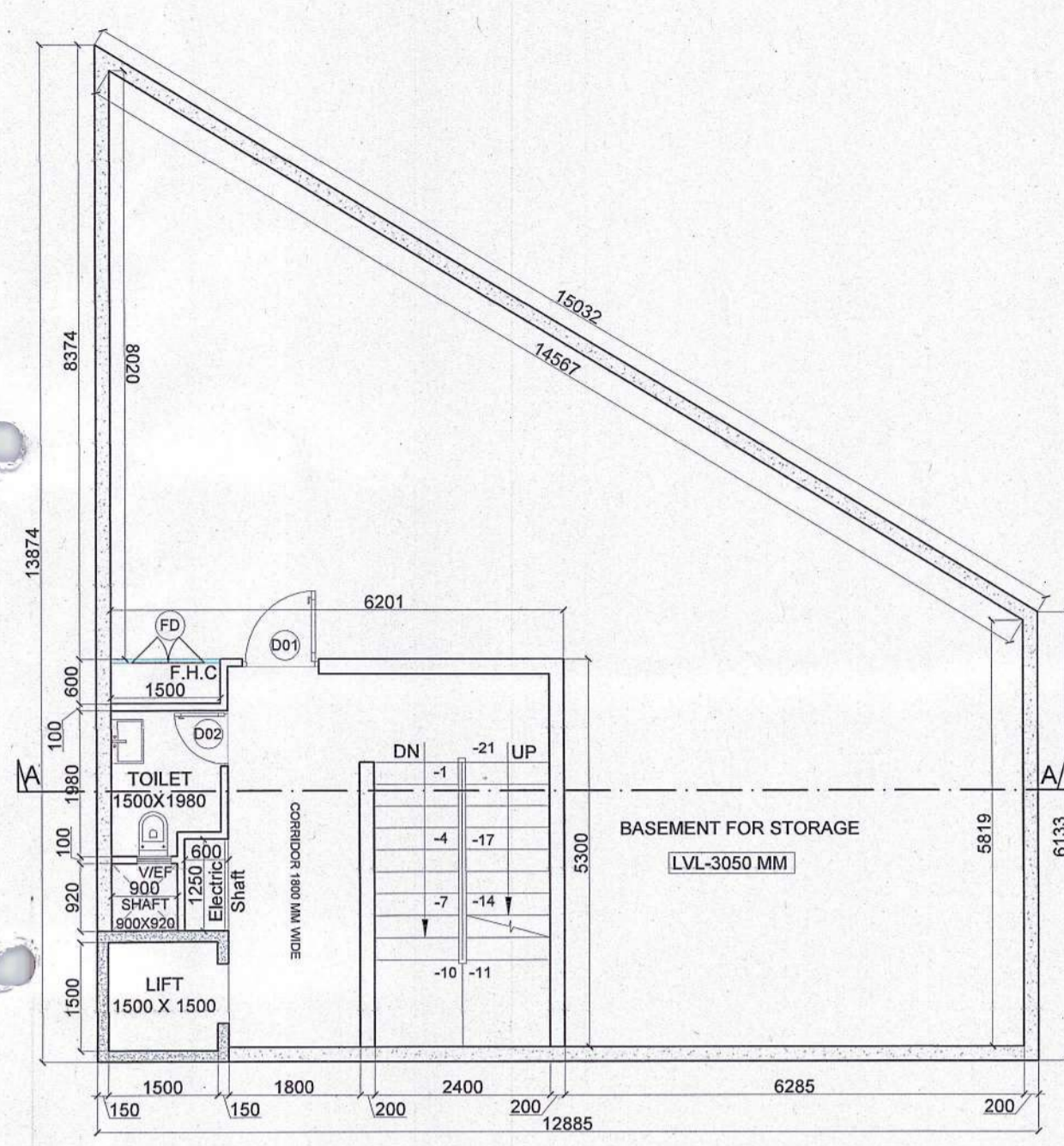

SCO Type-F1 - 128.899 SQMT (IRREGULAR)		
Description	Factor	Sq.Mts.
SCO Size		128.899
Permissible FAR	4.286	552.422
Proposed FAR	4.217	543.627
Remaining FAR	0.068	8.795
Proposed Built-up Area		742.998

AREA DETAIL (F1) - (128.899 SQMT IRREGULAR)								
S.No.	NAME	SHAPE	LENGTH (L)	WIDTH (B)	FORMULA	AREA	QUANTITY	TOTAL AREA
1	GROUND COVER	A	12.885	6.133	L X B	79.021	1	79.021
2	MEZZANINE FLOOR	C	12.885	7.742	BASE X HEIGHT	49.878	1	49.878
3	FIRST FLOOR FAR	D	12.885	6.133	L X B	79.021	1	79.021
4	SECOND FLOOR FAR	E	12.885	6.133	L X B	79.021	1	79.021
5	THIRD FLOOR FAR	F	12.885	6.133	L X B	79.021	1	79.021
7	TOTAL FAR IN SCO	B+C+D+E+F				543.627		543.627
8	MUMTY BUILT-UP AREA	H	2.800	5.500	L X B	15.400	1	15.400
9	MUMTY BUILT-UP AREA	I	2.800	5.500	L X B	15.400	1	15.400
10	NON FAR AREA	J				87.980		87.980
10	TOTAL BUILT-UP AREA IN SCO	B TO J				746.886		746.886

GROUND - COVERAGE & FAR								
S.No.	NAME	SHAPE	LENGTH (L)	WIDTH (B)	FORMULA	AREA	QUANTITY	TOTAL AREA
1	A	Rectangle	12.885	6.133	L X B	79.021	1	79.021
2	B	TRIANGLE	12.885	7.742	BASE X HEIGHT	49.878	1	49.878
TOTAL GROUND COVERAGE & FAR							128.899	

MEZZANINE FLOOR - FAR								
S.No.	NAME	SHAPE	LENGTH (L)	WIDTH (B)	FORMULA	AREA	QUANTITY	TOTAL AREA
1	A	Rectangle	12.885	6.133	L X B	79.021	1	79.021
2	B	TRIANGLE	12.885	7.742	BASE X HEIGHT	49.878	1	49.878
TOTAL MEZZANINE AREA							128.899	

FIRST, SECOND & THIRD FLOOR - FAR								
S.No.	NAME	SHAPE	LENGTH (L)	WIDTH (B)	FORMULA	AREA	QUANTITY	TOTAL AREA
1	A	Rectangle	12.885	6.133	L X B	79.021	1	79.021
2	B	TRIANGLE	12.885	7.742	BASE X HEIGHT	49.878	1	49.878
TOTAL FIRST FLOOR AREA							128.899	

BASEMENT FLOOR - NON FAR								
S.No.	NAME	SHAPE	LENGTH (L)	WIDTH (B)	FORMULA	AREA	QUANTITY	TOTAL AREA
1	A	Rectangle	12.885	6.133	L X B	79.021	1	79.021
2	B	TRIANGLE	12.885	7.742	BASE X HEIGHT	49.878	1	49.878
TOTAL BASEMENT FLOOR NON FAR AREA							128.899	

MUMTY BUILT-UP AREA DIAGRAM								
S.No.	NAME	SHAPE	LENGTH (L)	WIDTH (B)	FORMULA	AREA	QUANTITY	TOTAL AREA
1	C	Rectangle	2.800	5.500	L X B	15.400	1	15.400
TOTAL BUILT-UP AREA OF MUMTY							15.400	

NON FAR IN BUILT-UP - ALL FLOORS								
S.No.	NAME	SHAPE	LENGTH (L)	WIDTH (B)	FORMULA	AREA	QUANTITY	TOTAL AREA
1	1	Rectangle	2.400	5.100	L X B	12.24	4	48.960
2	2	Rectangle	1.500	1.500	L X B	2.25	4	9.000
TOTAL NON FAR							67.960	

DOOR WINDOW SCHEDULE			
	SIZE	CILL LEVEL	LINTEL LEVEL
FD	1000 X 1900	00MM	2400MM
D01	1250 X 2400	00MM	2400MM
D02	750 X 2100	00MM	2100MM
GL01	9235 X 2400	00MM	2400MM
GL02	5310 X 2400	00MM	2400MM
GL03	14000 X 2400	00MM	2400MM
V/EF	600 X 1200	1200MM	2400MM

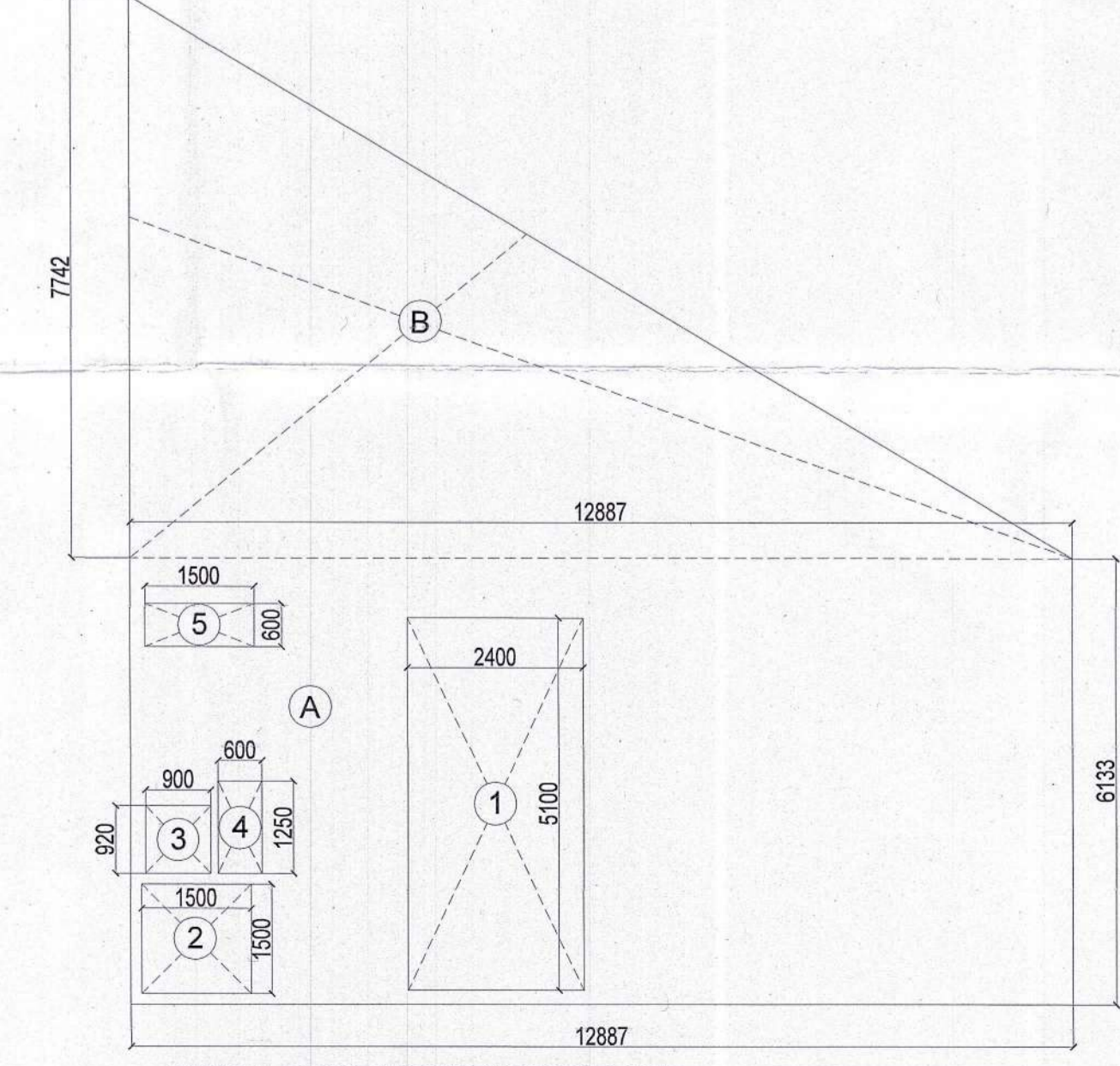
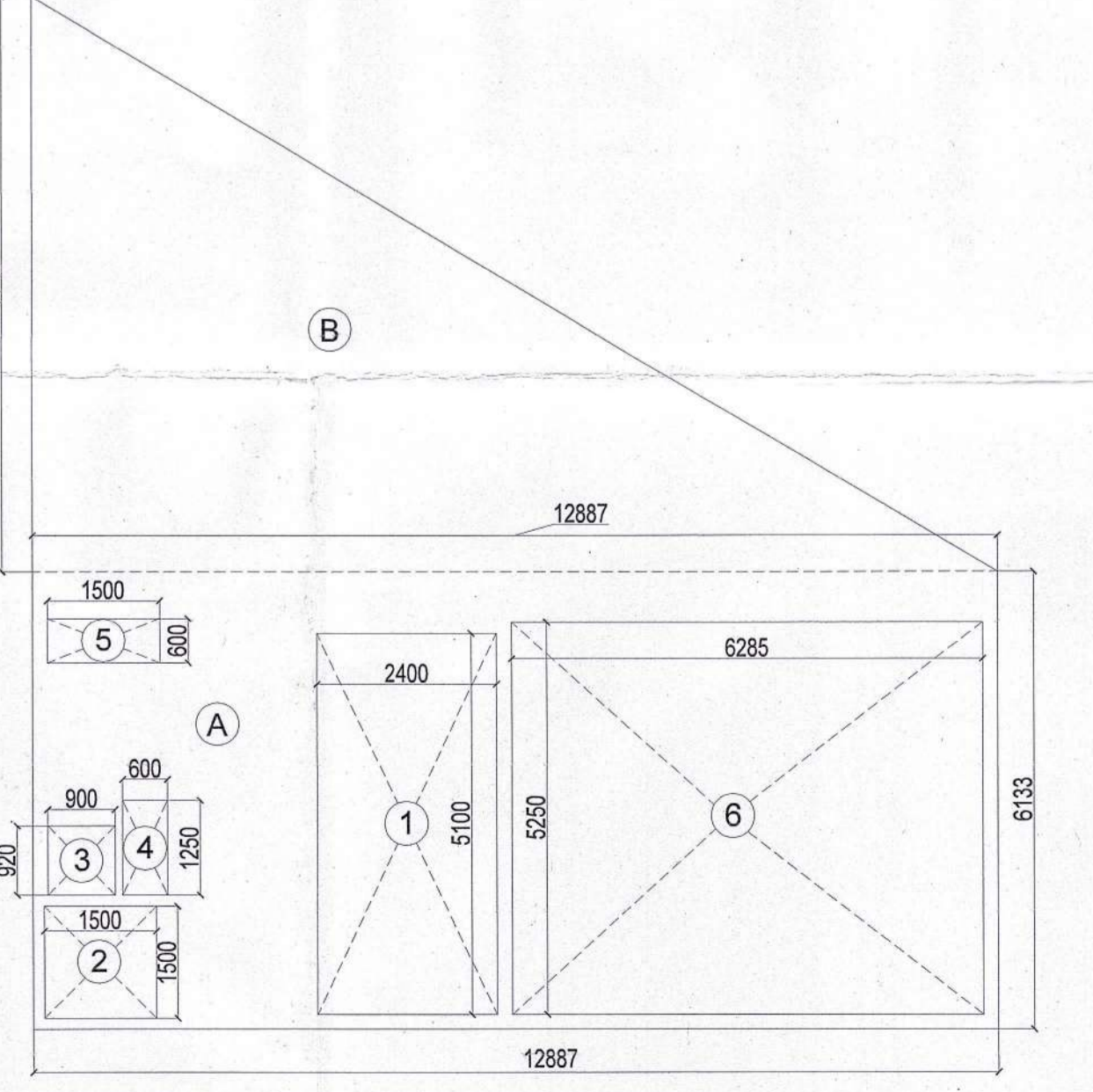
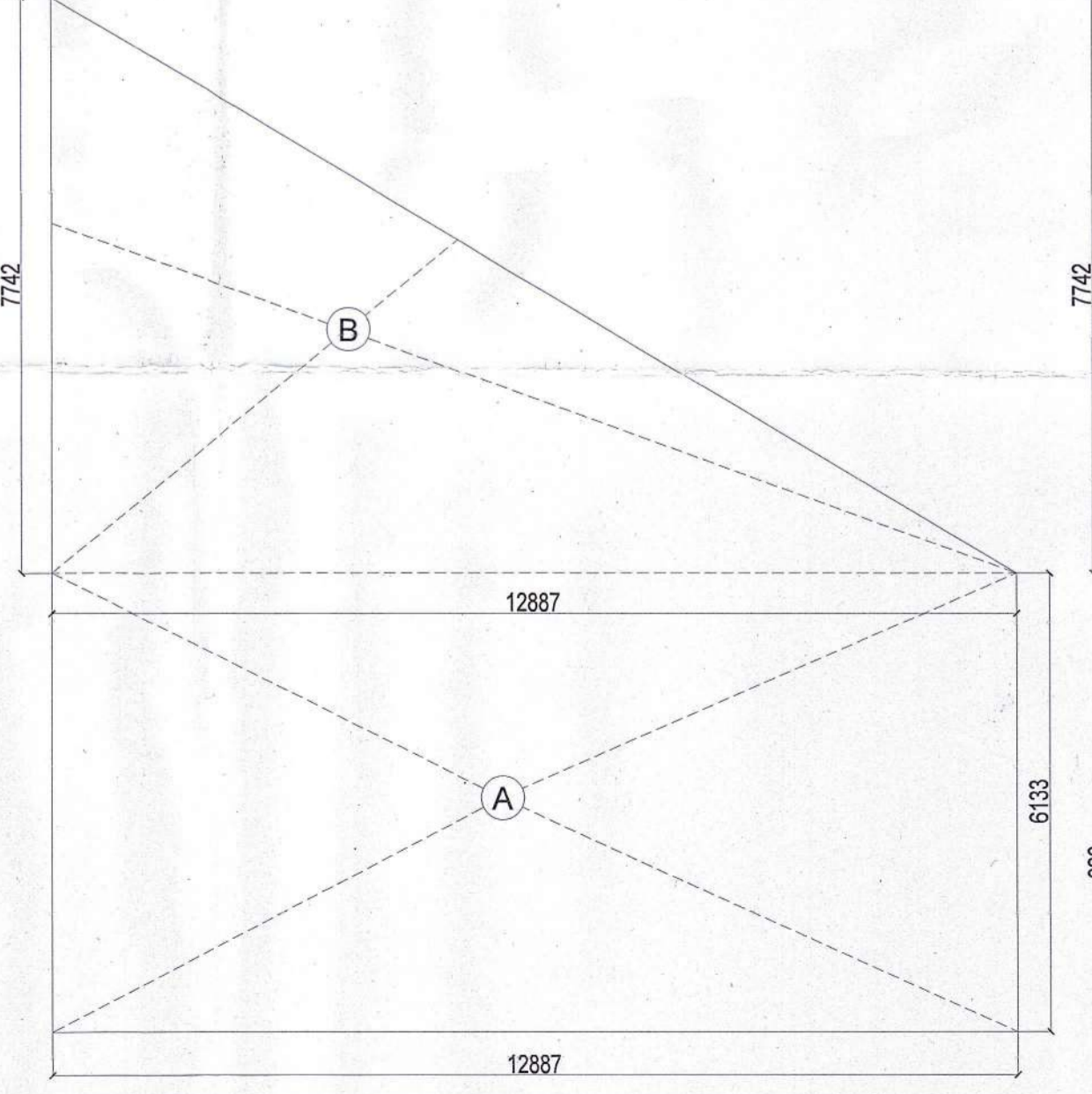
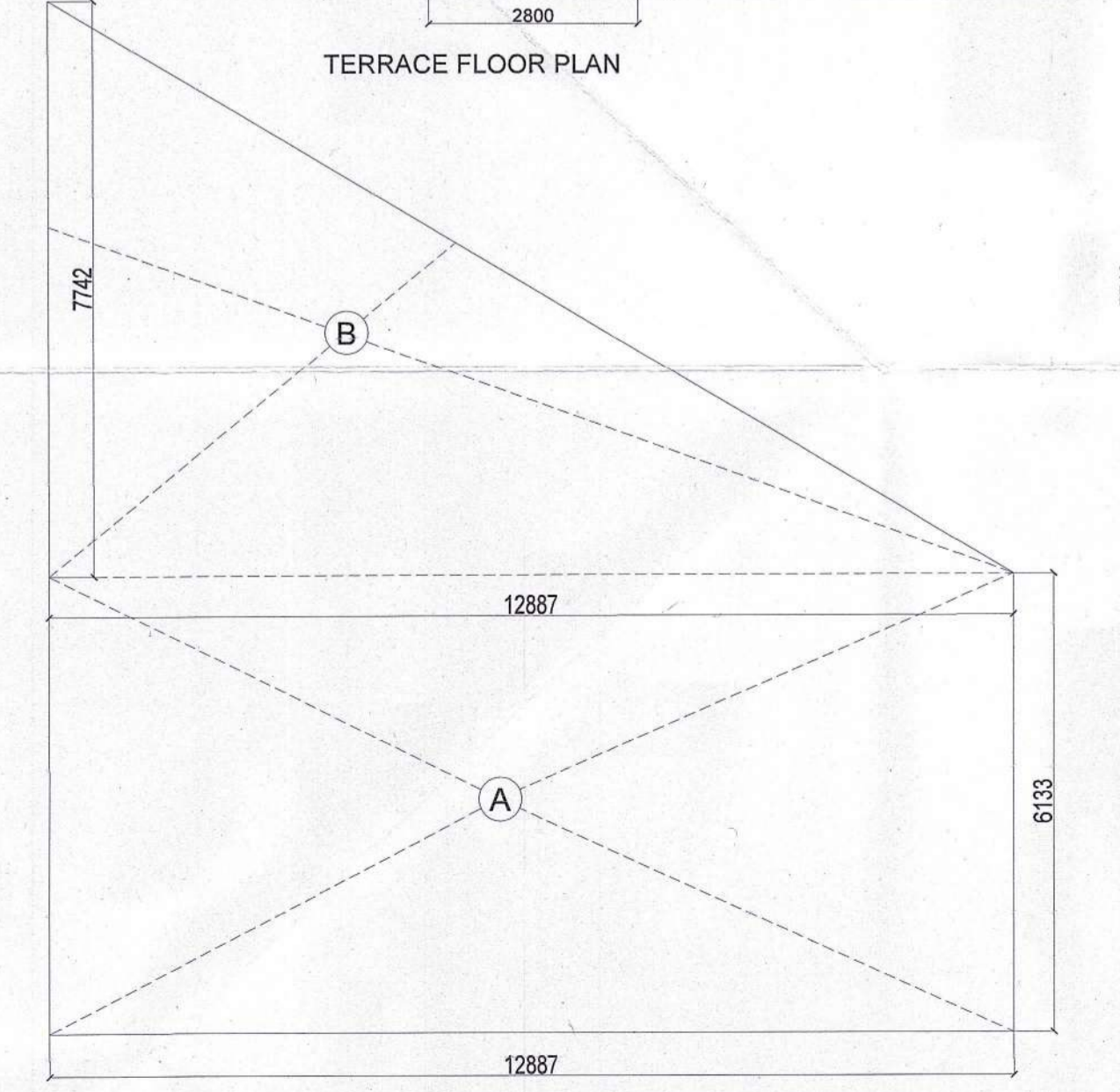
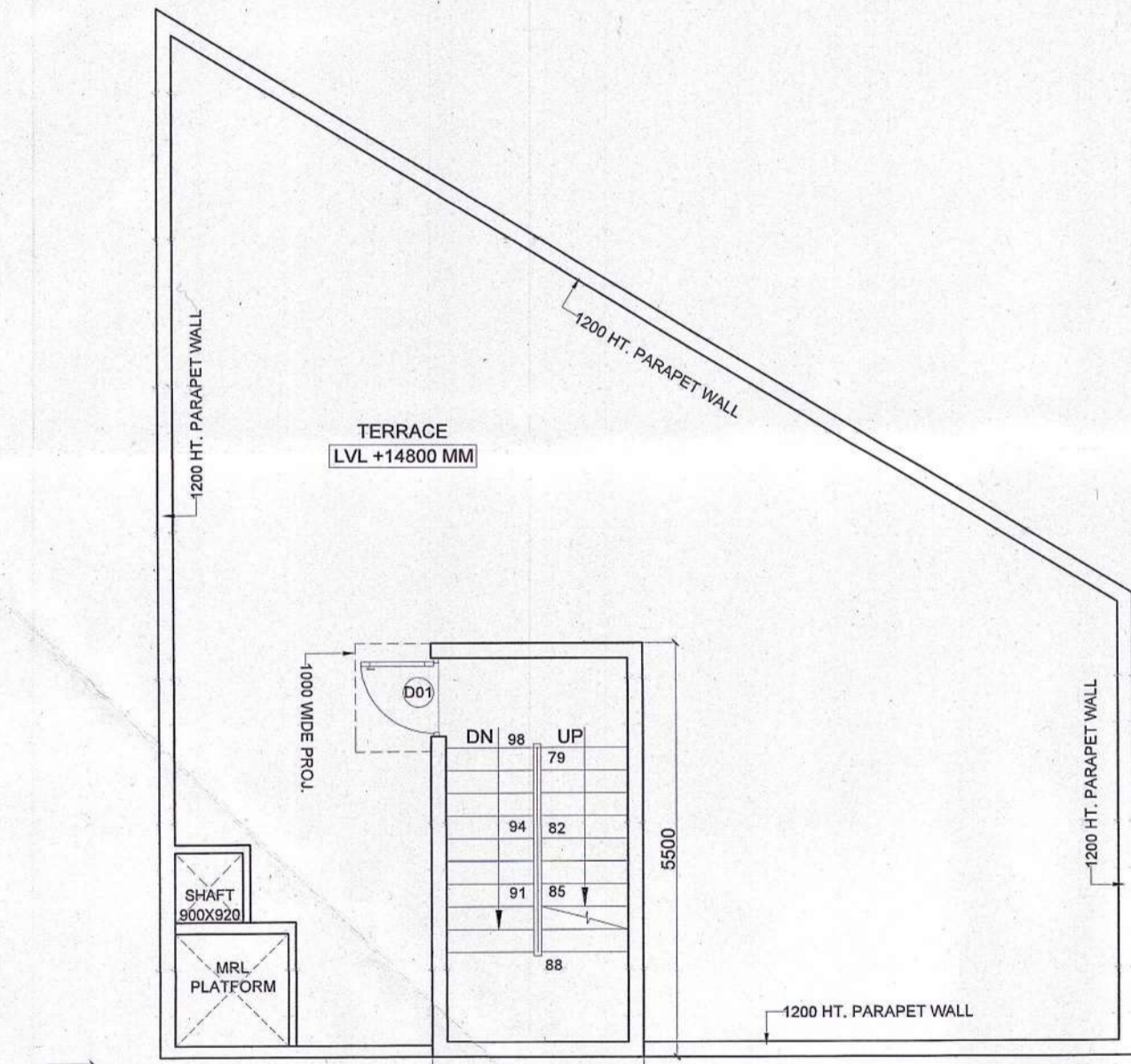
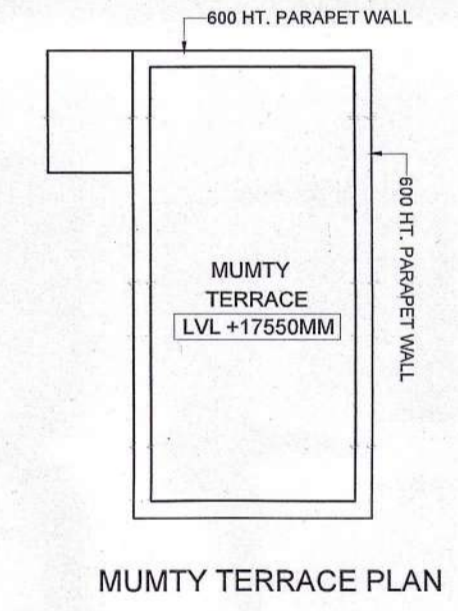
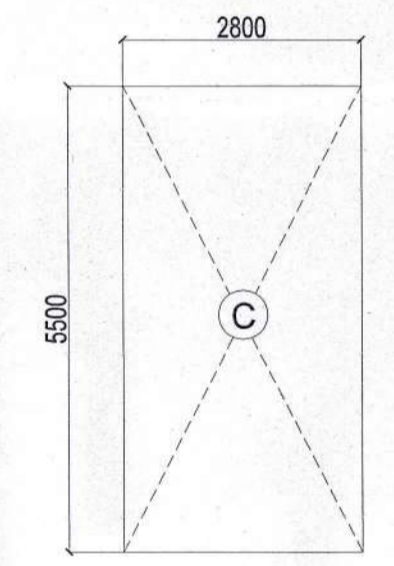

CLIENT:
GLS INFRAPROJECTS PVT. LTD.
 PROJECT:
 Commercial Plotted Colony (License No. 103 of 2021 Dated 08.12.2021 and License no. 145 of 2023 Dated 11.07.2023) on an Area Measuring 3.8375 Acres Situated in the Revenue Estate of Village Dhorka, Sector 95, Gurugram, Haryana Being Developed by GLS Infraprojects Pvt Ltd

DRAWING TITLE:
SCO Type -F1 (128.899 SQMT IRREGULAR) FLOOR PLANS & AREA DIAGRAMS

For GLS INFRAPROJECTS PVT. LTD.
 Authorised Signatory
VIMAL BAJAJ
 Architect CA/96/19791
 938, Sector-14, Gurgaon

OWNER'S SIGNATURE ARCHITECT'S SIGNATURE