

MUMTY FBUILT UP AREA								
1. ADDITION - XX								
S.No.	NAME	SHAPE	LENGTH (L)	WIDTH (B)	FORMULA	AREA	QUANTITY	TOTAL AREA
1	22	Rectangle	2.200	4.320	- L X B	9.504	1	9.504
2	23	Rectangle	3.300	6.000	- L X B	19.800	1	19.800
1. TOTAL ADDITION							29.304	SQM.
ADDITION (XX) - DEDUCTION							29.304	SQM.
TOTAL BUILT UP AREA							29.304	SQM.

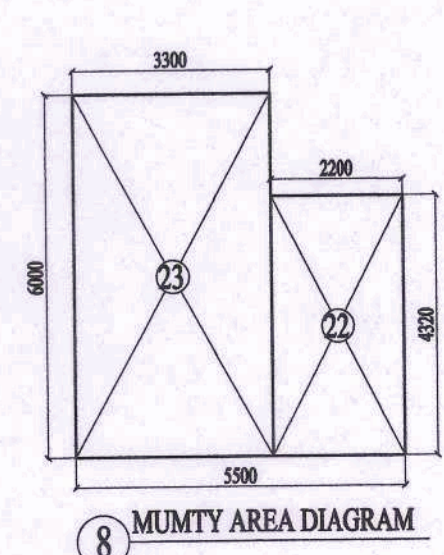
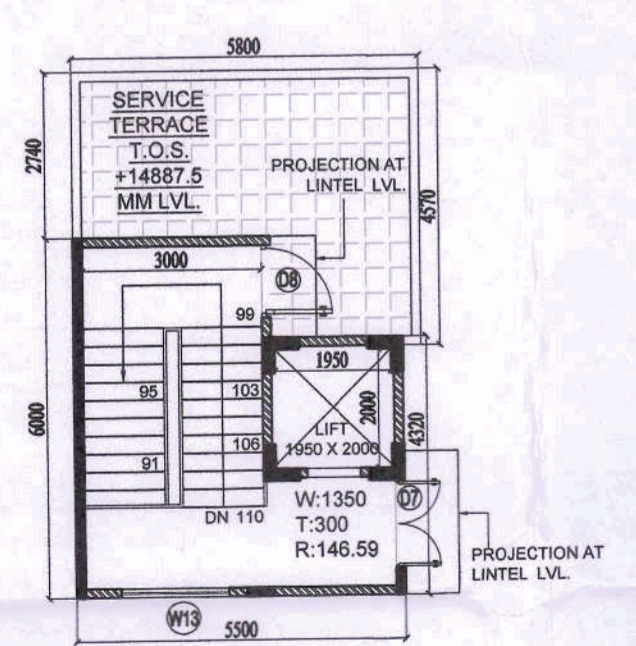
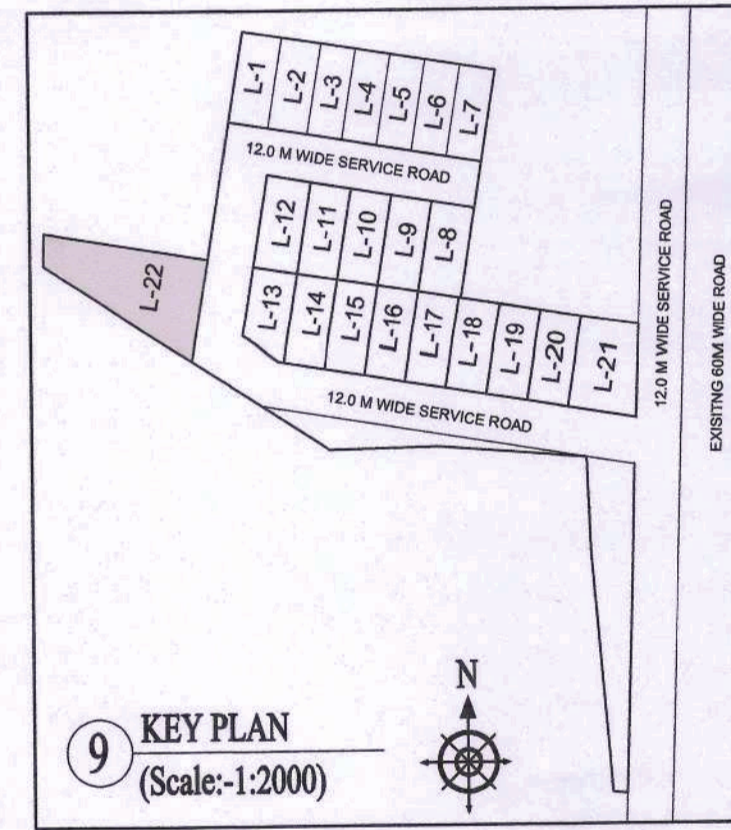

DOOR & WINDOW OPENING SCHEDULE						
TYPE	FLOOR	LOCATION	DOORS	SIZE	CILL	LINTEL
1	D1	TYPICAL FL.	STAIRCASE & M. BEDROOM	1500 X 2450	N.A.	2450
2	D2	TYPICAL FL.	TOILET-1	1200 X 2450	N.A.	2450
3	D3	TYPICAL FL.	DRESS-2	1100 X 2450	N.A.	2450
4	D4	TYPICAL FL.	TOILET-2, 3 & 4	850 X 2450	N.A.	2450
5	D5	TYPICAL FL.	S. ROOMS	750 X 2100	N.A.	2100
6	D6	TYPICAL FL.	S. ROOMS W.C.	700 X 2100	N.A.	2100
7	D7	TERRACE	MUMTY	1470 X 2200	N.A.	2200
8	D8	TERRACE	STAIR LANDING	1200 X 2100	N.A.	2100
9	GD1	TYPICAL FL.	LIVING DINING	2700 X 2600	N.A.	2600
10	GD2	STILT FLOOR	STAIRCASE	AS DESIGN	N.A.	BEAM BOTTOM
WINDOWS & SLIDING DOORS						
1	SD1	TYPICAL FL.	LIVING DINING	3500 X 2600	N.A.	2600
2	SD2	TYPICAL FL.	LIVING DINING	2470 X 2600	N.A.	2600
3	SD3	TYPICAL FL.	FAMILY LOUNGE	3070 X 2600	N.A.	2600
4	SD4	TYPICAL FL.	BEDROOM-3	1500 X 2600	N.A.	2600
5	SD5	TYPICAL FL.	BEDROOM-2	2760 X 2600	N.A.	2600
6	W1	TYPICAL FL.	POWDER RM., TOILET-2 & 3	750 X 2150	450	2600
7	W2	TYPICAL FL.	DINING FL.	3930 X 2150	450	2600
8	W3	TYPICAL FL.	KITCHEN	2620 X 1700	900	2600
9	W4	TYPICAL FL.	BEDROOM-3	2440 X 2150	450	2600
10	W5	TYPICAL FL.	TOILET-4	750 X 1400	1200	2600
11	W6	TYPICAL FL.	TOILET-1	1800 X 2150	450	2600
12	W7	TYPICAL FL.	PASSAGE	1530 X 2150	450	2600
13	W8	STAIR LANDING	S. ROOMS W.C.	450 X 900	1200	2100
14	W9	STAIR LANDING	S. ROOMS	1150 X 1200	900	2100
15	W10	TYPICAL FL.	STAIRCASE	1800 X 2150	450	2600
16	W11	STILT FL.	STAIRCASE	2700 X 2600	N.A.	2600
17	W12	STILT FL.	STAIRCASE	2050 X 2600	N.A.	2600
18	W13	TERRACE	MUMTY	1800 X 1750	450 FROM TERRACE	2200 FROM TERRACE

NOTE:
 1. ALL DIMENSIONS ARE IN MM UNLESS OTHERWISE SPECIFIED
 2. ALL WALLS ARE 150MM TH. AAC BLOCK WALL

PRINCIPAL ARCHITECT:

K-47, KAILASH COLONY, NEW DELHI-110048
 PHONE NO.: 011-46556600

OWNER'S SIGNATURE: **ARCHITECT'S SIGNATURE:**

PROJECT: Proposed Building Plan for Plot No. L-22, Block-L falling in Residential Plotted Colony Measuring 141.66875 Acres (License No. 64 of 2010 Dated 21.08.2010) at Brahma City, Sector-60, 61, 62, 63 & 65, Gurugram Manesar Urban Complex being developed by Adani Brahma Synergy Pvt. Ltd.

DRAWING TITLE:
 PLOT TYPE - I, PLOT NO. L22
 TYPICAL, TERRACE FLOOR PLANS & AREA DIAGRAMS

NORTH **SHEET NO.**
44