

AREA DETAIL : RESIDENTIAL & COMMERCIAL. Table with columns: TYPE OF BUILDING/TOWER, NO OF STORY, NO OF TOWER, TOTAL NO OF UNITS, POPULATION (PERSONS), GROUND COVERAGE / BLOCK (SQM), TOTAL GROUND COVERAGE (SQM), F.A.R PER TOWER (SQM), TOTAL F.A.R (SQM), STL AREA (NON F.A.R) SQM, TOTAL STL AREA (NON F.A.R) SQM, SERVICE FLOOR AREA (NON F.A.R) SQM, MULTI-STORY FROM 6.0M F.A.R) SQM. Includes sub-tables for Commercial F.A.R Calculation and Residential F.A.R Calculation.

POPULATION CALCULATIONS - MIN. AS PER OLD SANCTIONED / MAXIMUM POPULATION i.e. +10%. Two tables providing population estimates based on residential and commercial components, including provisions for earlier approvals.

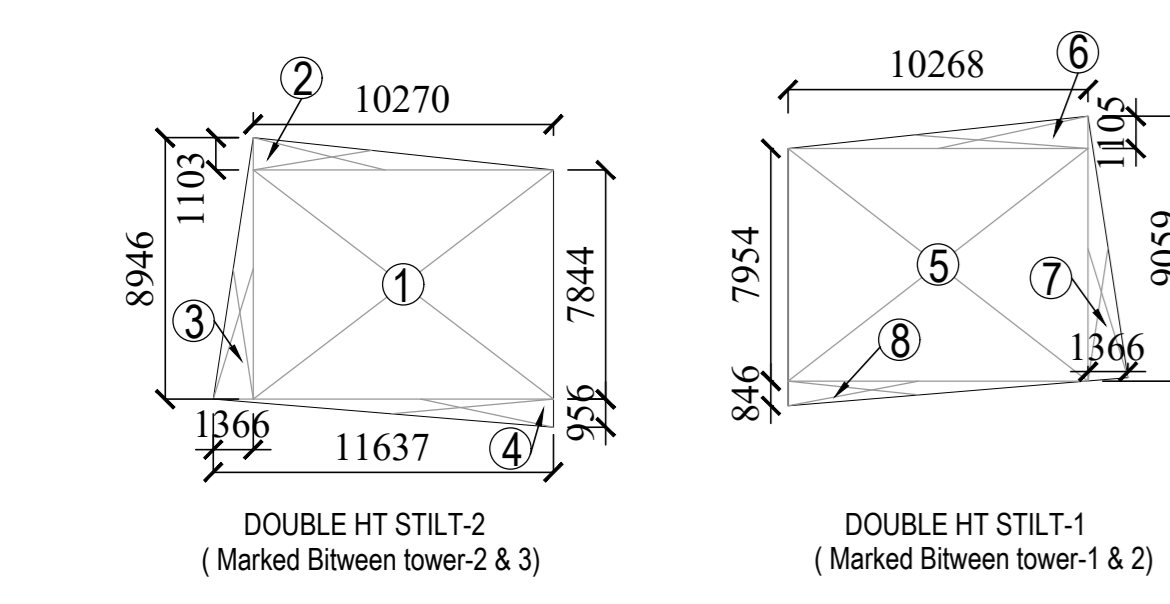

STY AREA DETAIL BETWEEN TOWER-8 & 2-3. Table with columns: NO SHAPE, AREA, DIMENSIONS. Includes formulas for area calculations of triangles and rectangles.

SURFACE PARKING AREA CALCULATION. Table with columns: NO SHAPE, B, H, TOTAL. Includes formulas for area calculations of rectangles, triangles, and trapeziums.

SWITCHING YARD AREA CALCULATION. Table with columns: NO SHAPE, B, H, TOTAL. Includes formulas for area calculations of trapeziums, triangles, and rectangles.