

**LEGEND**

- COMMERCIAL
- COMMUNITY FACILITY
- SERVICES
- GREEN

**SITE 03 & EXTENSION**

	PERMISSIBLE			PROPOSED		
	AREA ACRES	AREA SQ.MTS.	PERCENTAGE %	AREA ACRES	AREA SQ.MTS.	GROSS PLOT AREA PERCENTAGE %
TOTAL Licence Area	10.55625	42719.560				
Area falling under Sector Road and Master Plan green	0.1077	435.846				1.02
Balance Area (A)	10.44855	42283.715				98.98
Open Area under GREEN/PARK	0.792	3203.967	7.50	0.804	3252.458	7.61
Community Facilities	1.056	4271.956	10.00	1.056	4272.000	10.00
Commercial Area	0.422	1708.782	4.00	0.422	1707.970	4.00
Area Under Plots	6.439	26058.932	61.00	4.874	19724.062	46.17
Total permissible Residential + Commercial area	6.862	27767.714	65.00	5.296	21432.032	50.17
Permissible Density		240-400 ppa	Plots required	187.67		
Achieved Density		240.43 ppa	Proposed Plots	188.00		

**LAND AREA CALCULATION**

S.NO.	LENGTH (M)	BREADTH (M)	AREA (SQ.M.)	CAL FORMULA
A	15.00	6.71	100.61	LxB
B	38.00	6.71	254.87	LxB
C	12.00	6.71	80.48	LxB
D	47.41	6.71	317.96	LxB
E	6.71	15.09	101.21	LxB
F	55.32	50.29	2782.09	LxB
G	184.40	20.12	3710.19	LxB
H	202.18	70.42	14237.14	LxB
I	60.07	25.15	1510.39	LxB
J	184.46	60.35	11131.98	LxB
K	1.68	60.35	50.57	(LxB)/2
L	142.49	48.62	6927.30	LxB
M	65.38	11.74	767.22	LxB
N	63.70	11.74	747.55	LxB
Total			42719.56	

PAT  
JE Rom  
SD  
ATP  
BTP (P)  
(16M)

**CLASSIFICATION OF PLOTS**

TYPE	SIZE OF PLOT		AREA OF PLOT SQ.MTS.	NO. OF PLOTS	TOTAL AREA OF PLOTS SQ.MTS.
	MTS.	MTS.			
A	7.80	19.23	149.99	7	1049.96
B	6.70	19.40	129.98	40	5199.20
C	6.70	16.95	113.57	4	454.26
D	6.70	14.00	93.80	81	7597.80
D'	6.70	15.10	101.17	14	1416.38
J	5.70	17.22	98.15	36	3533.54
J'	5.63	14.00	78.82	6	472.92
TOTAL				188	19724.06

**COMMERCIAL AREA CALCULATION**

S.NO.	LENGTH (M)	BREADTH (M)	AREA (SQ.M.)	CAL FORMULA
C1	16.95	26.80	454.26	LxB
C2	45.93	27.30	1253.71	LxB
Total			1707.97	

**O.C.F. AREA CALCULATION**

S.NO.	LENGTH (M)	BREADTH (M)	AREA (SQ.M.)	CAL FORMULA
O1	43.07	46.71	2011.71	LxB
O2	43.45	9.66	419.84	LxB
O3	39.62	13.67	541.57	LxB
O4	23.69	54.84	1298.77	LxB
Total			4272.00	

**GREEN AREA CALCULATION**

S.NO.	LENGTH (M)	BREADTH (M)	AREA (SQ.M.)	CAL FORMULA
1	24.73	26.80	662.79	LxB
2	58.61	15.51	908.88	LxB
3	5.63	6.00	33.78	LxB
4	5.74	23.30	133.81	LxB
5	0.50	23.30	5.82	(LxB)/2
6	21.48	11.15	239.47	LxB
7	21.48	9.00	193.31	LxB
8	21.48	17.22	369.93	LxB
9	16.83	22.98	386.79	LxB
Total			3252.45	

**FROZEN PLOTS DETAILS**

TYPE	SIZE OF PLOT		AREA OF PLOT SQ.MTS.	NO. OF PLOTS	TOTAL AREA OF PLOTS SQ.MTS.
	MTS.	MTS.			
A	7.80	19.23	149.99	7	1049.96
B	6.70	19.40	129.98	20	2599.60
D	6.70	14.00	93.80	42	3939.60
J	5.70	17.22	98.15	24	2355.70
J'	5.63	14.00	78.82	6	472.92
TOTAL				99	9944.85

**50.42 % PLOT FROZEN BY DEPARTMENT AREA**  
9944.85 SQ.MTS / 2.46 ACRES

**GREEN AREA CALCULATION**

	SQ.M.	ACRES
G1	1922.827	0.4415
G2	1329.623	0.3029
TOTAL	3252.450	0.7444

**VEGETABLE/MILK BOOTH**

	MTS.	MTS.	SQ.MTS.
	5.00	5.50	27.50
TOTAL			27.50

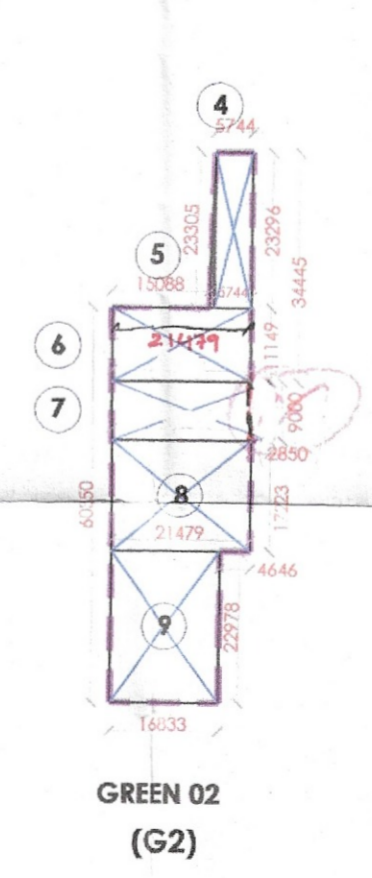
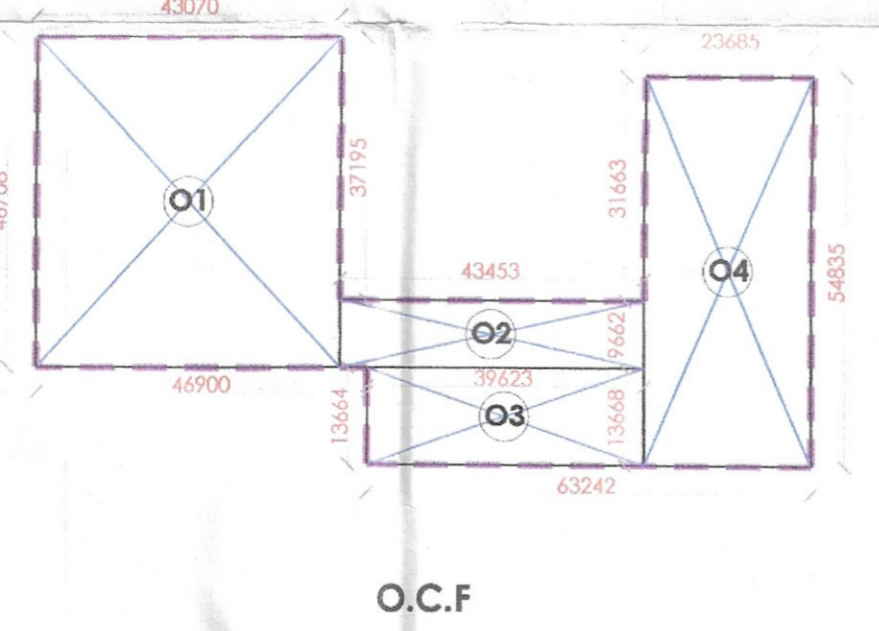
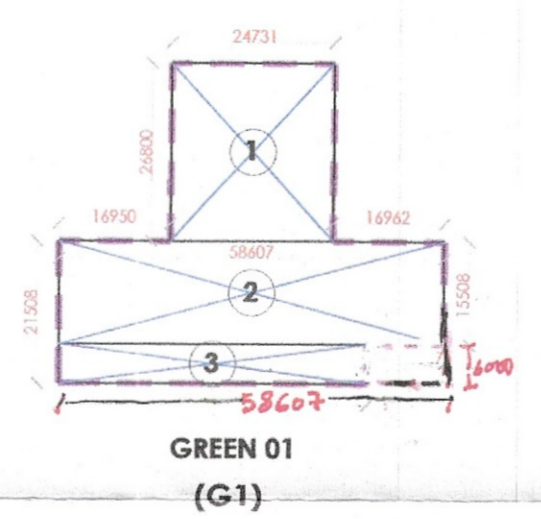
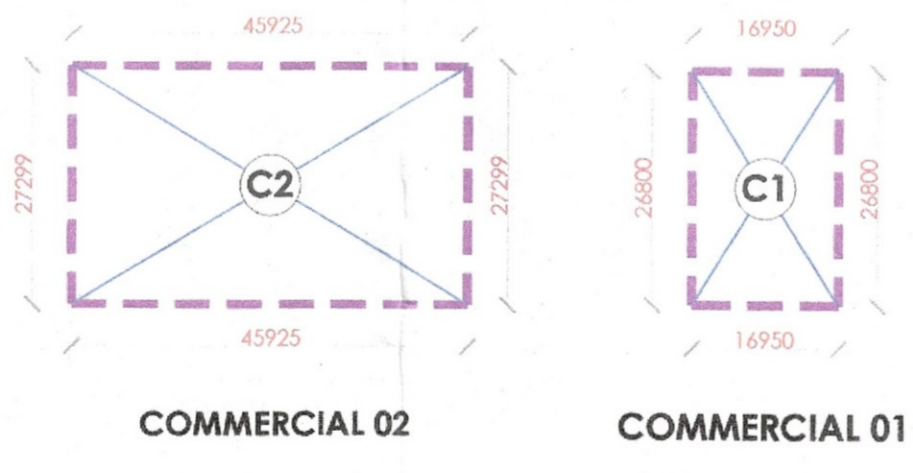
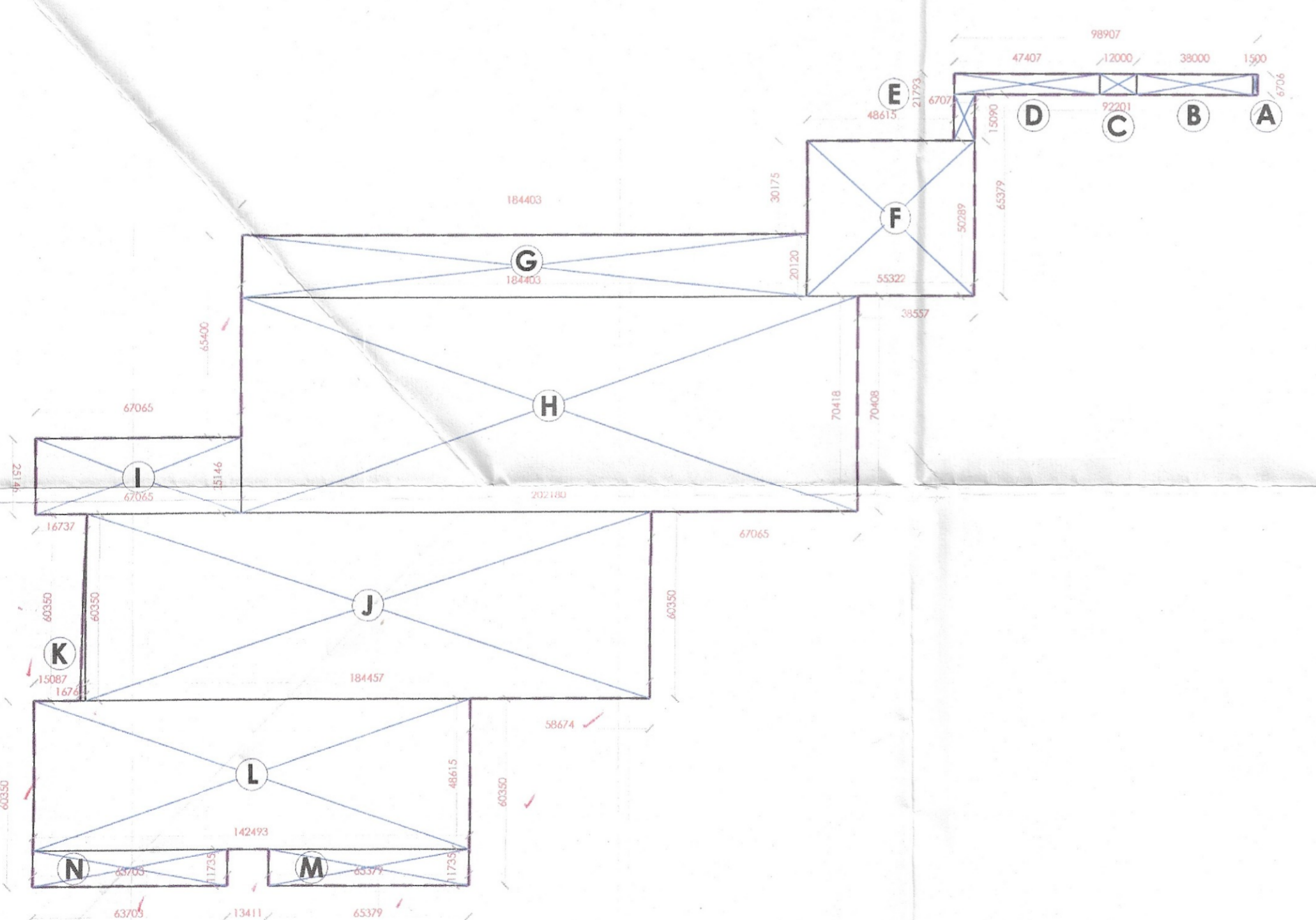
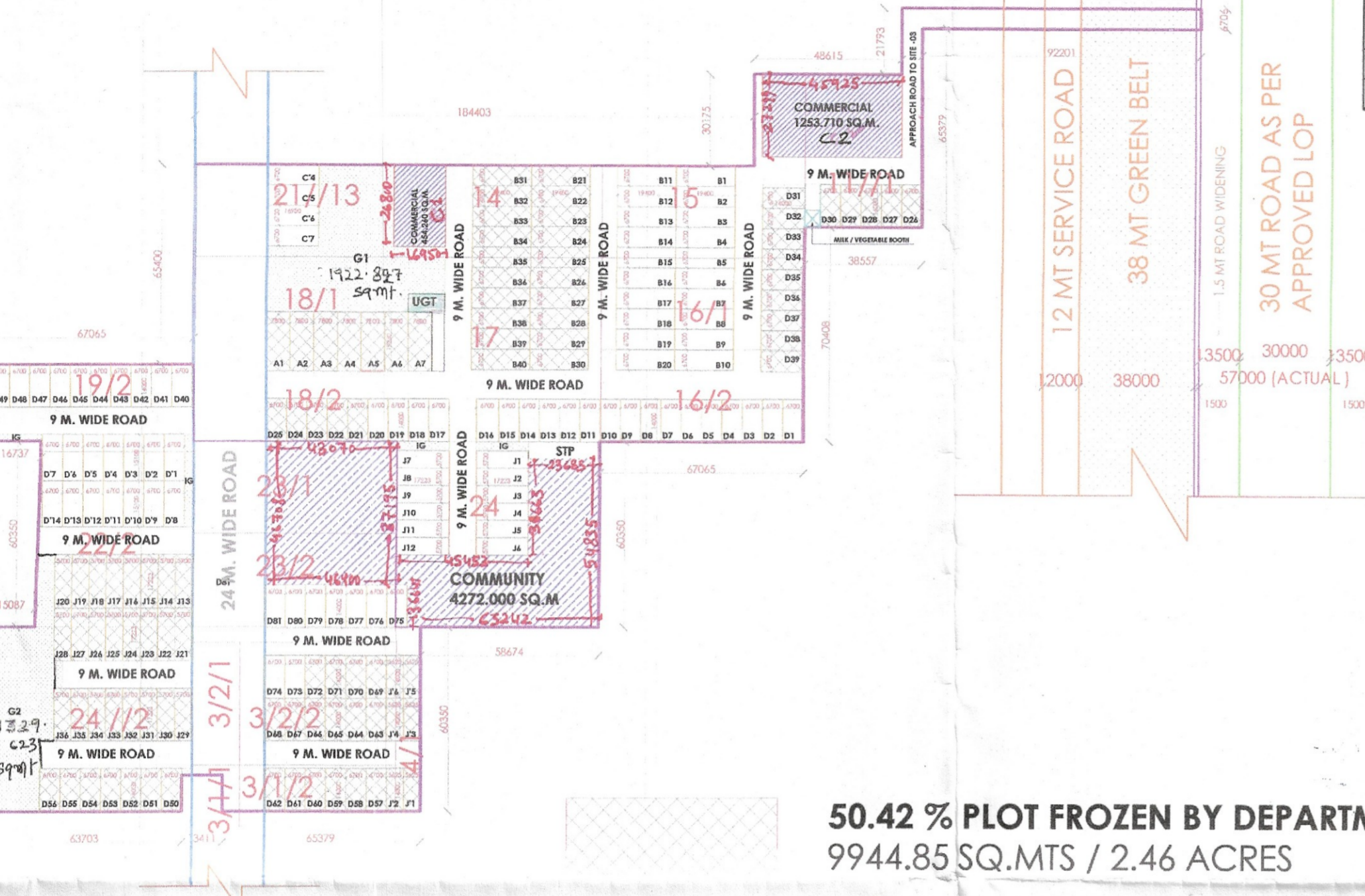

PROJECT NAME AND ADDRESS:  
DEMARCATION PLAN CUM REVISED SITE LAYOUT PLAN OF PROPOSED RESIDENTIAL PLOTTED COLONY UNDER DDJAY, IN SECTOR-36, SOHNA, OVER AN AREA OF 10.55625 ACRES BEING DEVELOPED BY SIGNATURE GLOBAL HOMES PVT. LTD

OWNER'S NAME:  
M/S SIGNATURE GLOBAL HOMES PVT. LTD

DRAWING NAME:  
DEMARCATION PLAN CUM REVISED SITE LAYOUT PLAN

ARCHITECT'S SIGNATURE:  
MANISH JAIN (ARCHITECT)  
Regd. No. CA/2001/26163  
E-131, East of Kailash, Lower Ground Floor, New Delhi-110065

OWNER'S SIGNATURE:

NORTH: DATE: SHEET: 01 SCALE:

