

PRODUCED BY AN AUTODESK STUDENT VERSION

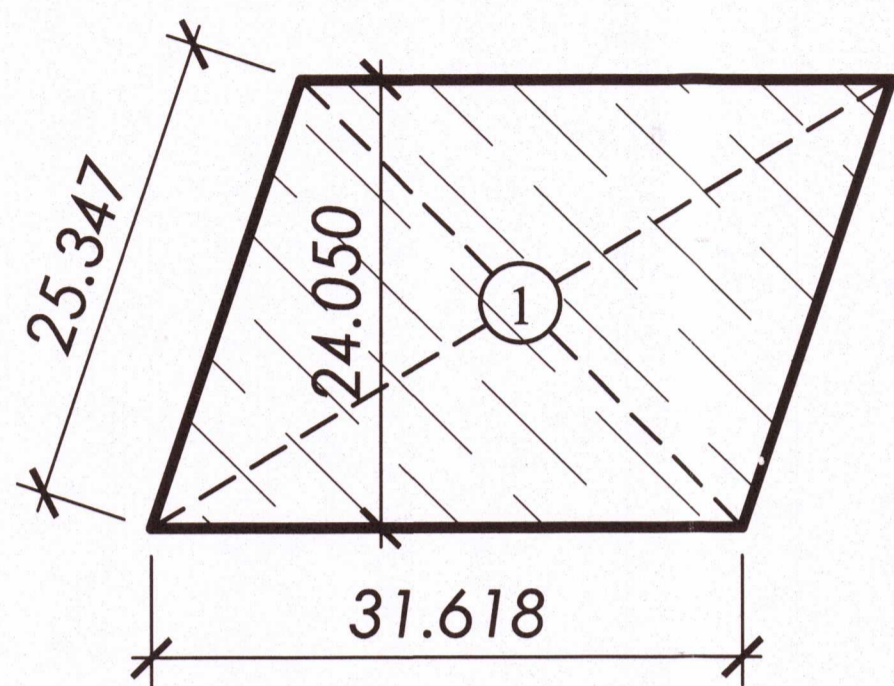

AREA UNDER GREEN BELT

TABLE 2
DETAIL OF AREA UNDER GREEN BELT

S NO.	LENGTH	WIDTH	AREA	REMARKS
1	31.618	24.050	760.4129	Parallelogram
TOTAL AREA IN SQM.			760.4129	
TOTAL AREA IN ACRES			0.19	

TABLE 3
DETAIL OF AREA UNDER HT. LINE BUFFER

S NO.	LENGTH	WIDTH	AREA	REMARKS
1	37.071	24.050	891.5576	Parallelogram
2	$(24.688+31.136)/2$	26.242	366.2334	Trapezium
3	$(31.136+7.869)/2$	50.292	980.8197	Trapezium
4	$(14.047+7.869)/2$	25.146	137.7749	Trapezium
TOTAL AREA IN SQM.			2376.3856	
TOTAL AREA IN ACRES			0.59	

AREA UNDER HT. LINE BUFFER

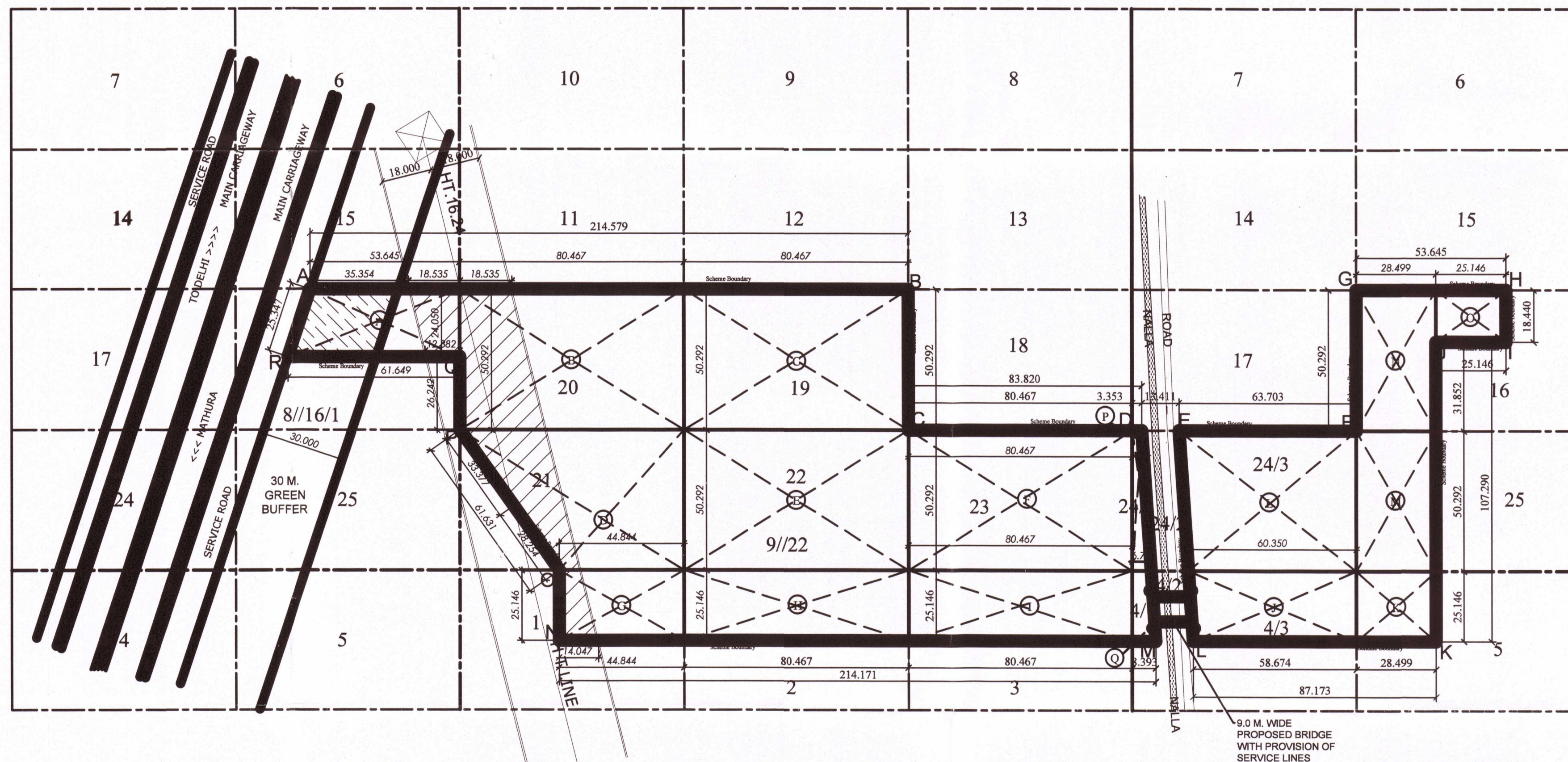
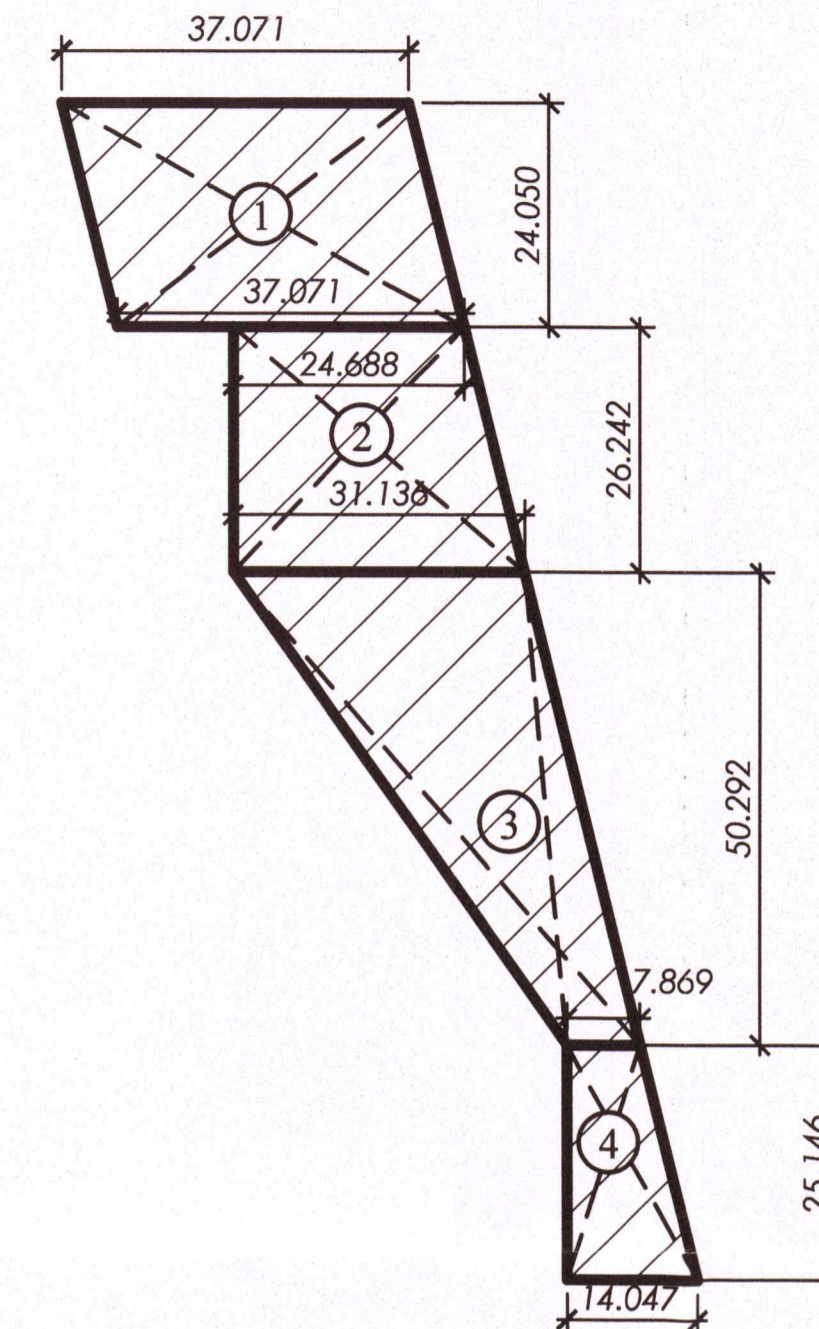

- 1. TOTAL AREA AT SITE = 8.65 ACRES. 35005.2042 SQM. (SHOWN IN TABLE 1)
- 2. AREA UNDER GREEN BELT = 0.19 ACRES 760.4129 SQM. (SHOWN IN TABLE 2)
- 3. AREA UNDER HT. LINE BUFFER = 0.59 ACRES 2370.3856 SQM. (SHOWN IN TABLE 3)
- 4. BALANCE AREA = 7.87 ACRES 31874.4057 SQM.

NOTE:-

- 1. ALL THE DIMENSIONS ARE IN METER UNLESS OTHERWISE SPECIFIED.

TABLE 1
AREA CALCULATION

Killa NO.	S NO.	LENGTH	WIDTH	AREA	REMARKS	K-M
8//16/1	A	$(53.645+61.649)/2$	24.050	1386.4104	Trapezium	2-15
9//20	B	80.467	50.292	4046.8464	Rectangle	8-0
9//19	C	80.467	50.292	4046.8464	Rectangle	8-0
9//21	D	$(80.467+44.844)/2$	50.292	3151.0704	Trapezium	6-5
9//22	E	80.467	50.292	4046.8464	Rectangle	8-0
9//23	F	80.467	50.292	4046.8464	Rectangle	8-0
13//1	G	44.844	25.146	1127.6472	Rectangle	2-5
13//2	H	80.467	25.146	2023.4232	Rectangle	4-0
13//3	I	80.467	25.146	2023.4232	Rectangle	4-0
13//4/3	J	$(60.35+58.674)/2$	25.146	1496.4888	Trapezium	2-18
13//5	K	28.499	25.146	716.6359	Rectangle	1-8
9//24/3	L	$(60.35+63.703)/2$	50.292	3119.4367	Trapezium	6-3
9//25	M	28.499	50.292	1433.2717	Rectangle	2-17
9//16	N	28.499	50.292	1433.2717	Rectangle	3-15
9//16	O	25.146	18.440	463.6922	Rectangle	
9//24/1	P	$(3.353+6.713)/2$	50.292	253.1196	Trapezium	0-10
13//4/1	Q	$(6.713+8.393)/2$	25.146	189.9277	Trapezium	0-8
TOTAL AREA IN SQM.				35005.2042		
TOTAL AREA IN ACRES				8.6500		

PROJECT TITLE
PROPOSED AFFORDABLE GROUP HOUSING FOR ADVITYA RESIDENCY LLP, MEASURING 8.65 ACRES, SECTOR 143, SIKRI, FARIDABAD.

DRAWING TITLE
DEMARCATIION PLAN

Field Surveyor: Rahul Kumar
 Drawn by: Hemendra Kumar Sharma
 Checked by: Hemendra Kumar Sharma
GEOGRAPHICAL PROJECT SERVICES
 LAND SURVEYORS & ENGINEERS
 OFFICE: H-2604, SAINIK COLONY, SEC-49 NIT, FARIDABAD (HARYANA)-121001
 PHONE:-0129-2435252, MOBILE:-9810023875
 WWW.GEOPROJECTSERVICES.COM



DATE: 31-10-2019
 SCALE: 1:1000
 DRG. NO.:

For Advitya Residency LLP
 Designated Partner

GENESIS
 SCF - 7, 2nd Floor,
 Sector-14 Market, Faridabad
 ARCHITECT
 ANURAG KAPOOR
 CA/98/23888

ARCHITECTS
 AR. ANURAG KAPOOR
 CA/98/23888
 AR. RITU KAPOOR
 CA/99/24290
Genesis
 ARCHITECTS, INTERIORS, LANDSCAPING & EXHIBITIONS.
 STUDIO :SCF 7, SECOND FLOOR, SEC 14 MKT. FARIDABAD, PHONE 0129 - 4109687

PRODUCED BY AN AUTODESK STUDENT VERSION