

IMP. LEVELS

1. lower basement level(finished floor lvl) = - 6200 lvl.
2. upper basement lvl(finished floor lvl) = - 2650 lvl.
3. extended basement roof top slab = + 100 lvl.
4. I.R.lvl.(fire passage) = + 1700 lvl.
5. O.R.lvl. / Dwarka Expressway Lvl. = ± 00 lvl.
6. LAWN LVL. = + 1750 lvl.
7. lower ground floor = + 2000 lvl.
8. floor to floor height = 3150 mm

NOTE - 1

- (1) COMMON AREA SUNKEN BY 25 MM.
- (2) BALCONY AREA SUNKEN BY 40 MM.
- (3) TOILET SUNK BY 50 MM.
- (4) FOR CUT OUT IN FIRE / L.V / ELECTRICAL SHAFT REFER ELECTRICAL DRG
- (5) FOR LOCATION AND DETAIL OF SUMP REFER PLUMBING DRG

NOTE - 2

- (1) MECHANICAL VENTILATION CUT-OUT TO BE PROVIDED
- (2) GROUND FLOOR RAILING TO BE FIXED LATER ON AFTER COMPLETION

NOTE :

OVERALL LAYOUT TO BE CHECKED BY A SENIOR PERSON AND DISCREPANCIES (IF ANY) SHALL BE IMMEDIATELY BROUGHT TO THE NOTICE OF MANAGEMENT AS WELL AS ARCHITECT

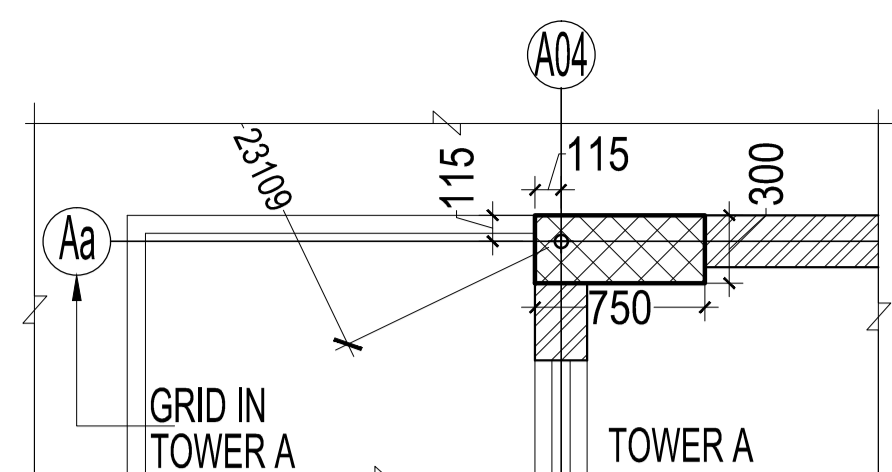
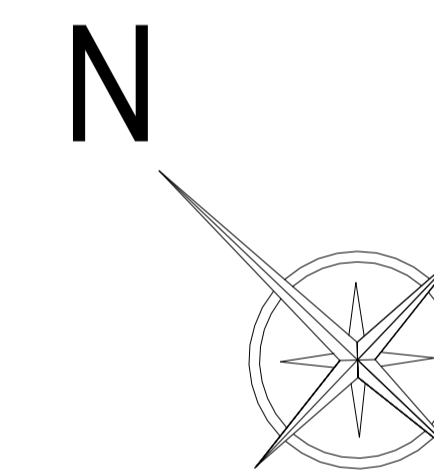

DETAIL A

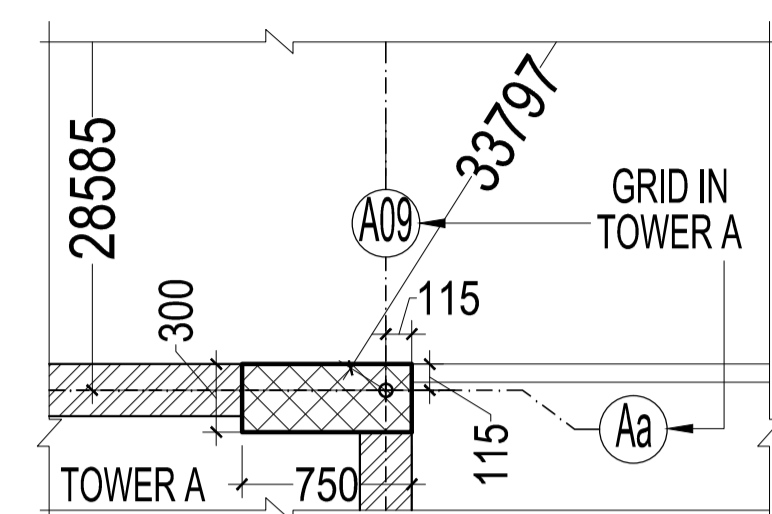

DETAIL B

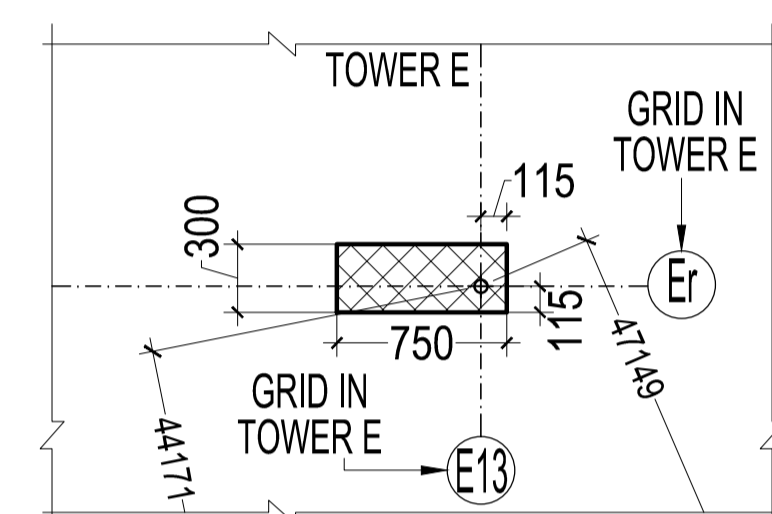

DETAIL C

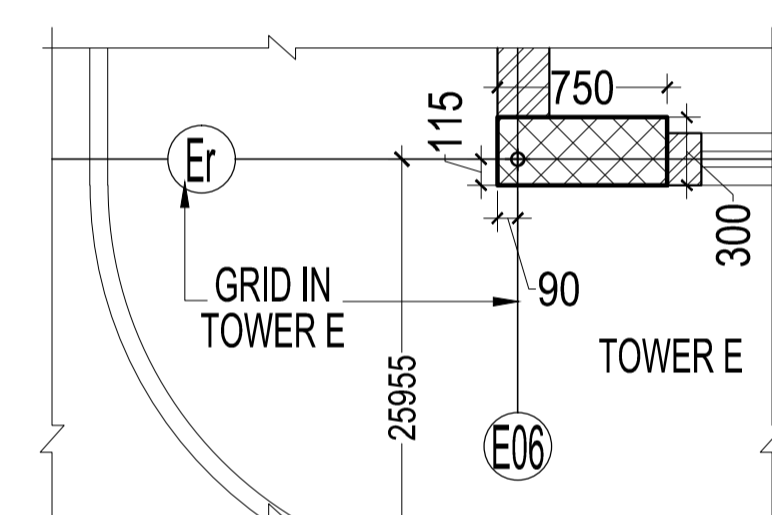

DETAIL D

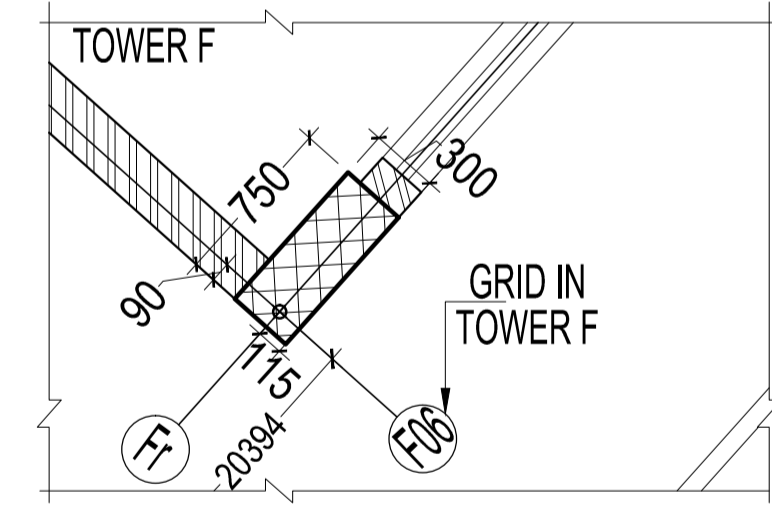

DETAIL E

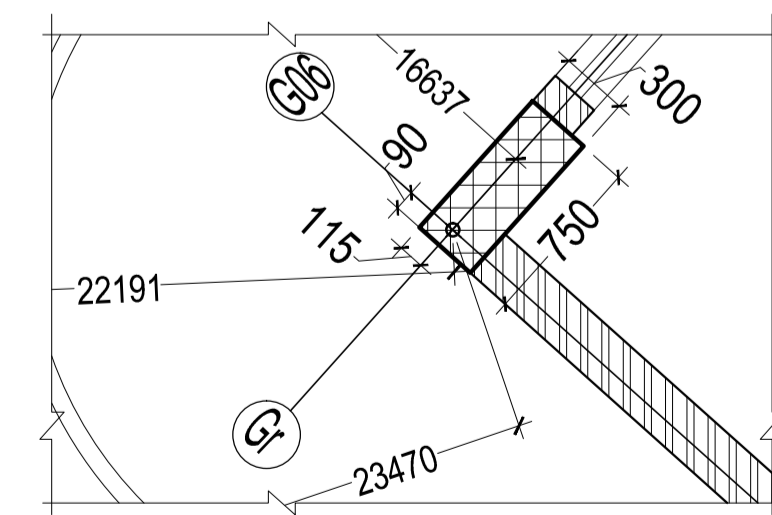

DETAIL F

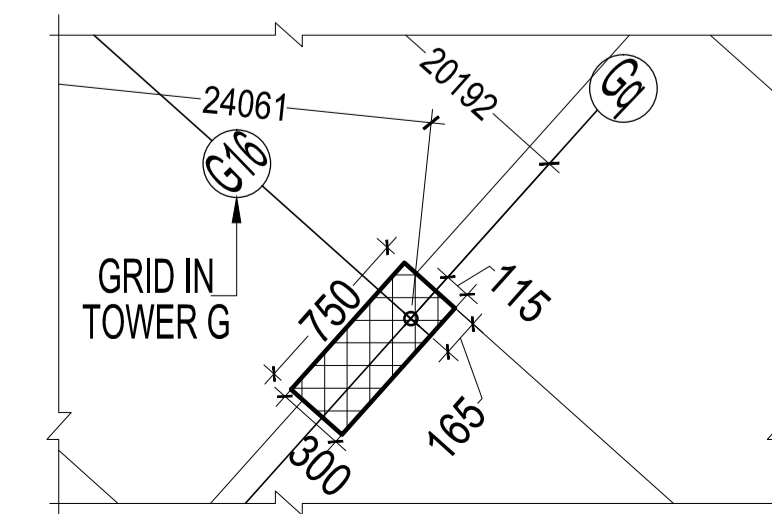

DETAIL G

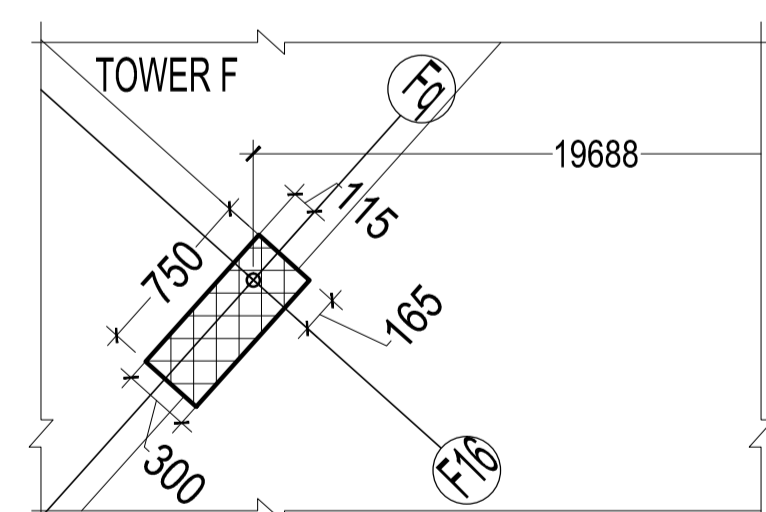

DETAIL H

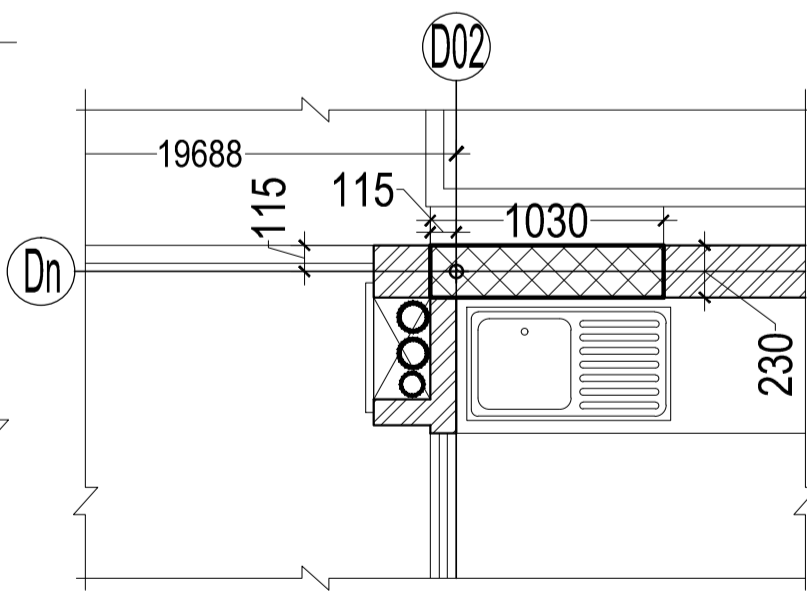

DETAIL I

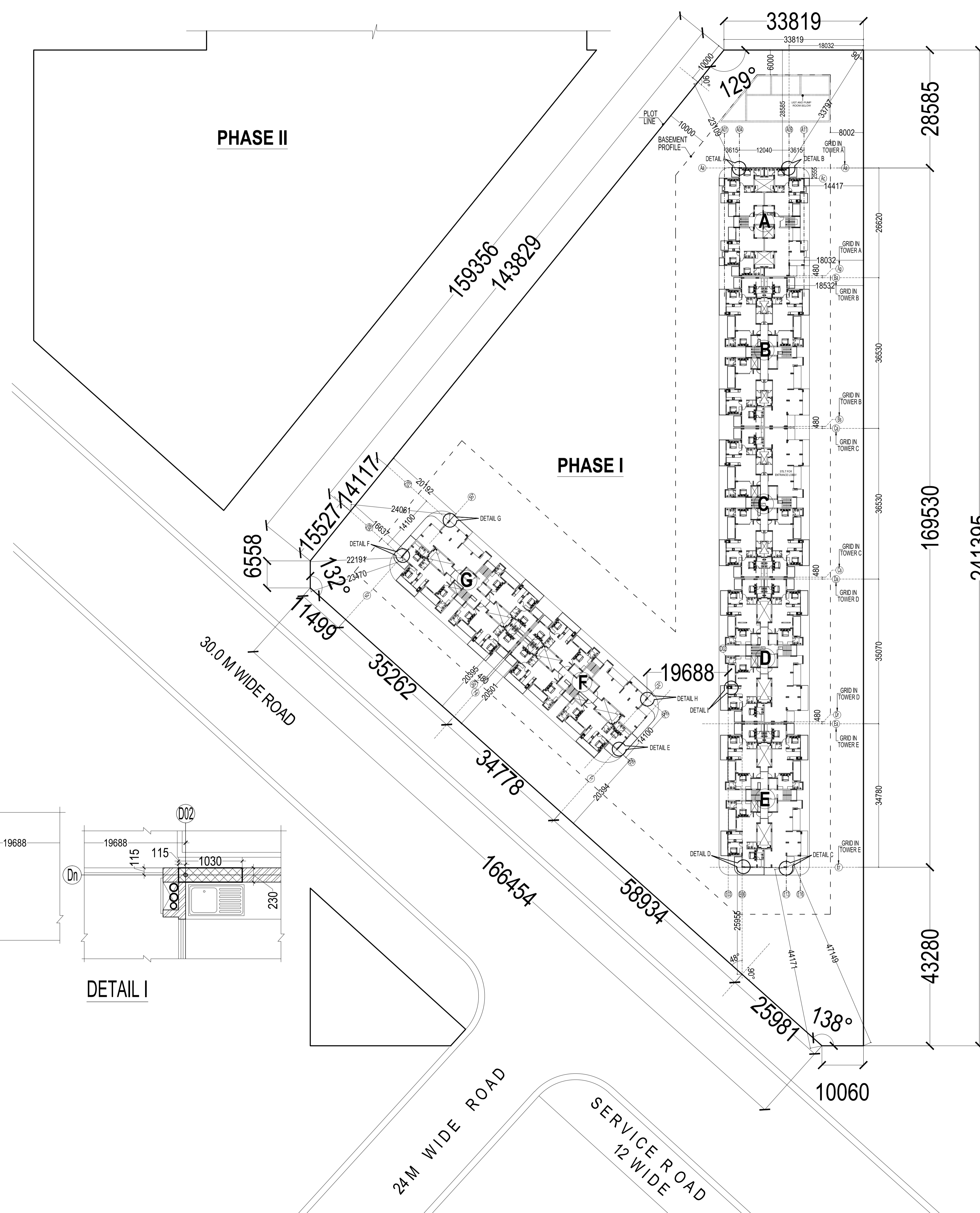

rev. no.	date	revision
..	..	..

PROJECT NAME:

TASHEE

PROJECT TITLE :

PROPOSED GROUP HOUSING COLONY MEASURING 10.462 ACRES(License No. 34 of 2011 Dated 16.04.2011)IN SEC-110A & 111, GURGAON MANESER URBAN COMPLEX BEIGN DEVELOPED BY M/S K.N.S INFRACON PVT.LTD.AND OTHERS

DRAWING TITLE :

SITE DEMARICATION PLAN SL-01 DWG NO.

SCALE	N.T.S
DATE	20130530
DEALT	
JOB NO.	COMP 2/D-DATATASHEEARCH. WORKING (PHASE-I)TOWER A

Architects:  
DEEPAK MEHTA & ASSOCIATES  
ARCHITECTS, PLANNERS, VALUERS, LANDSCAPE & INTERIORS  
SECOND FLOOR, PLOT NO. 16, ABHISHEK PLZA, L.S.C. MAYAPUR VIHAR PH II, DELHI - 110091, INDIA  
TELEPHONE : 91 - 11 - 65272180, 91 - 11 - 22770180, TELEFAX : 91 - 11 - 22770180  
Website : www.indian-architect.com E-mail : deepakmehta1962@gmail.com

DRAWING RELEASED FOR:

- APPROVAL  SUBMISSION  
 ADVANCE COPY  CONSTRUCTION

ARCHITECT'S SIGN OWNER'S SIGN