

**PROJECT REPORT**  
**for**  
**COMMERCIAL PLOTTED COLONY**  
**“EMAAR BUSINESS DISTRICT 89”**



**At**  
**Village-Badha**  
**Sector 89, Gurgaon, Haryana**

**EMAAR**

**M/s Emaar India Ltd.**

## **TABLE OF CONTENTS**

<b>1.0</b>	<b>INTRODUCTION</b>	<b>3.0</b>
<b>2.0</b>	<b>SITE LOCATION AND SURROUNDINGS</b>	<b>3.0</b>
<b>3.0</b>	<b>PROJECT DETAILS</b>	<b>5.0</b>
<b>4.0</b>	<b>CONCLUSIONS</b>	<b>12.0</b>

## 1.0 INTRODUCTION

The project is a Commercial Plotted Colony to be developed by M/s Emaar India Ltd. The site is located at village Badha, Sector – 89, Gurgaon, Haryana on a land admeasuring 3.70625 Acres and referred to as “proposed project”. The proposed project has been named as “**Emaar Business District 89**”. M/s Emaar India Ltd. are successful in providing specifically designed solutions to the elite professional keeping in mind their daily needs and their exquisite taste in lifestyle.

The project is based on following objectives:

- To provide for modern shopping/office experience.
- To enhance the surrounding with greenery, landscaping and recommended aesthetics.
- To adopt the practice of plantation and rain water harvesting to create a better micro climate in the area.
- To recharge Ground Water by proposing Rainwater Harvesting System.

As already mentioned, the proposed site is spread over an area of 3.70625 Acres (14998.70 sq m). It is proposed to develop 52 number of plots with ground coverage of 5247.38 sq m and FAR area of 22498.048 sq m. All the infrastructure/amenities like water supply, sewage line, storm water line, STP, road network, power, etc. will be provided for the proposed project. It is proposed to have utility block of 37.661 sq m.

The site is located on Sector-89/90 on 75 m wide sector road. It is proposed to have 0.419 acres (1694.881 sq m) as green/landscape area. Approximately 1.500 (6069 sq m) is earmarked for roads and pavements. The tentative date for start of the project is November 1, 2021 and completion date is October 31, 2026. The layout is enclosed as Annexure I

## 2.0 SITE LOCATION AND SURROUNDINGS

The proposed project is located at village – Badha, Sector –89, Gurgaon, Haryana. The coordinates of the project site are 31°44'36.9"N and 69°04'07. 9"E with site elevation of 232 MSL. Site location on Master Plan and Survey of India toposheet showing project site & surroundings is given below:

# MASTER PLAN

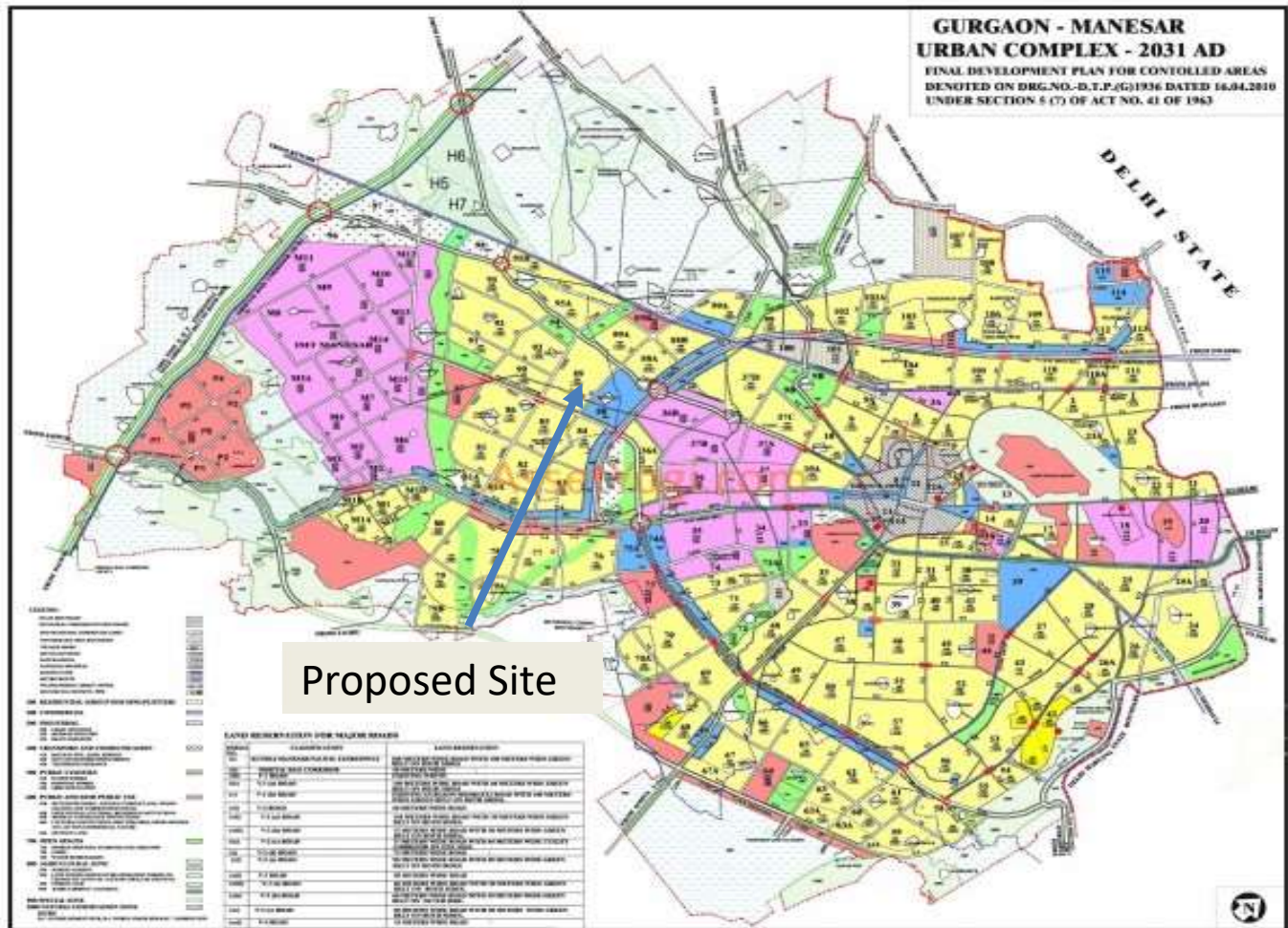

## CONNECTIVITY

The project site is well connected through 75 m wide road. The nearest highway is NH-8 which is 6.5 km away from project site. Gurgaon railway station is about 13 km away and the nearest airport is Indira Gandhi International Airport is at 27 km from the proposed project site. The connectivity is shown as below:

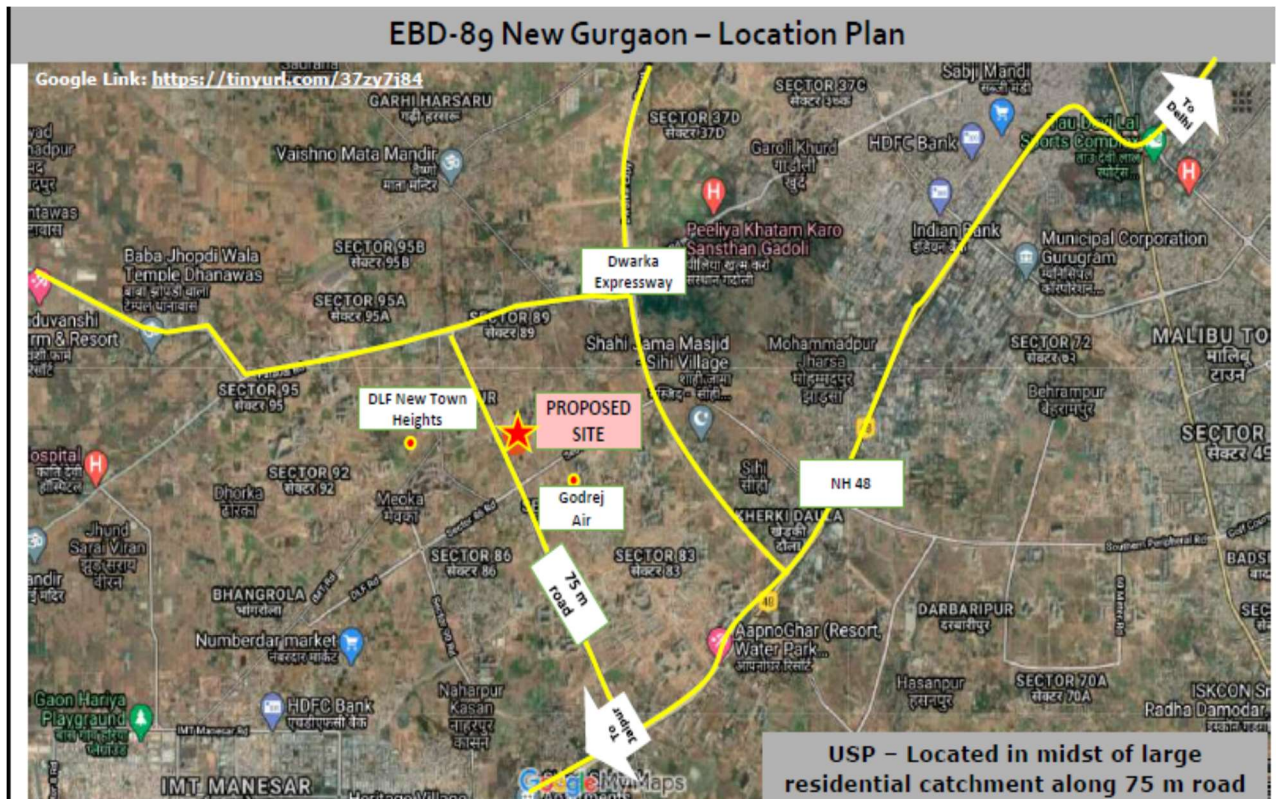

### 3.0 PROJECT DETAILS

As already mentioned, the total area of proposed project is located is 3.70625 acres. The License has been issued by Directorate of Town & Country Planning, Government of Haryana as License No. 52 of 2021 dated 18.08.2021. This project would be developed as single phase.

The project details are given in Table 1.0 below:

**Table 1.0: Project Details**

S. No.	Particulars	Remarks
1.	Total Plot Area	14998.70 sq m
2.	Total FAR Area	22498.048 sq m
3.	Ground Coverage	5247.38 sq m
4.	Nos. of units	52
5.	Height	<15.0 m
6.	Greenbelt	15%
7.	Water requirement	~168 KLD
8.	Waste water	~110 KLD
9.	STP Capacity	STP of 140 KLD
10.	Power requirement	2250 KVA
11.	Solid Waste	~180 kg per day

12.	Parking	Surface parking
13.	Rain Water Harvesting	4 pits
14.	Total Cost of project	~Rs. 72.89 Crores
15.	Total Population	1650 (including floating/visitors)
16.	Total Floors	G+4

## POPULATION DENSITY

### Population Density:

The population for the proposed project has been calculated as per NBC norms taking 3 sq m/per person, 6 sq m/per person and 10 sq m/per person for ground, first and second-fourth respectively. The total population including floating/visitor would be 1650 out of which 165 would be fixed population.

## VEHICLE PARKING FACILITIES

### Parking Proposed:

It is proposed to have an area of 0.402 acres (1625.00 sq m) earmarked for parking.

## POWER REQUIREMENT

The power supply shall be supplied by DHBVNL (Dakshin Haryana Bijli Vitaran Nigam Limited). The total demand load for the complete project is estimated to be 2250KVA. The power requirements have been assessed on the basis of DHBVNL Sales Circular No. D-16/2017 dated April 12, 2017 and D- 26/2019 dated July 10, 2019

## WATER & WASTEWATER DETAILS

Water would be sourced through pipeline supply of Gurugram Metropolitan Development Authority (GMDA). The total fresh requirement for the project would be ~60. The landscaping and flushing requirement amounting to 77 KLD would be met from recycled water of Sewage Treatment Plant and excess if any would be discharged to GMDA sewer.

### **Sullage Generation & Treatment**

It is expected that the project will generate approx. ~110 KLD of sewage that would be treated in Sewage Treatment Plant (STP) of 140 KLD capacity to be installed at site. The treated

wastewater will be used for flushing, horticulture and rest will be discharged to GMDA sewer. The Sewage Treatment Plant will be based on Sequential Batch Reactor (SBR) technology.

### **Sewage Treatment Details**

#### **SEQUENTIAL BATCH REACTOR (SBR TECHNOLOGY)**

Sewage generated from the project during operational phase will be treated in sewage treatment plant proposed of 140 KLD capacities at the project site within the premises. As required by MoEF&CC treatment will be done to achieve treated effluent to permissible limit to reuse for various non-domestic applications.

#### **Design Consideration/Process detail of Sewage Treatment Plant**

##### **Design Basis**

S.No.	Parameter	Unit	Inlet	Post Equalization	Post SBR	Post Filtration
1	pH		6.5-8.5	6.5-8.5	6.5-8.5	6.5-8.5
2	BOD	mg/l	250-300	175-225	<30	<10
3	COD	mg/l	600-800	400-500	<50	<15
4	TSS	mg/l	300-450	<200	<20	<10
5	Oil and Grease	mg/l	Up to100	<10	<5	<2

##### **Process / Schematic**

Incoming Sewage → screening → oil and Grease Separation → Collection to Equalization Tank → Pumping to Reactor → Aeration, Settling and Decanting → Filtration → Disinfection and storage.

Batch Process Tanks are designed for 5 Batches.

##### **Technology Description**

Sequential Batch Reactor is simple yet a controlled process with good degree of automation to perform the functions in batches. The SBR has four major steps, as given below, completed in about four hours per batch:

Fill	1.5 Hrs
React / Aerate	2.0 Hrs
Settle	0.5 Hrs
Decant	0.5 Hrs

Total duration for a single Batch is 4.5 Hrs.

### **Process Description**

In order to ensure quality of treated effluent for various uses, Sewage Treatment Plant has been designed to ensure that the treated sewage (water) is well below the permissible limits, even under the varying flow conditions which are typical for such developments. The main components of the process adopted for the STP include the following:

- Incoming sewage before collecting in the equalization tank, trash and oil will be removed through screen chamber and oil & grease trap. Coarse Bubble Diffusers will be provided in Equalization tank to avoid anaerobic condition.
- The sewage from the equalization tank will be lifted by pumps to the Sequential Batch Reactor (SBR). These pumps will have enough capacity to pump the entire batch in one hour, as per the time cycle.
- Aeration in SBR tank will be done by fine bubble diffusers with the help of air blower. After filling the SBR tank with sewage, blower will start and once biodegradation has taken place, blower will be shut off for some time to allow settling of the sludge. After settling, the decanting process will start. Decanter is designed to decant one batch in 0.5 Hrs. Moving type decanter will be designed to obtain the desired efficiency. Decanter will be provided with scum guard.
- Aeration system and decanting system will be automated for smooth operation. Level sensor is mounted in SBR tank to prevent overloading and under loading.
- Decanted water will be stored in intermediate storage tank. Decanted water will be first fed in Multi-grade sand filter for removing any suspended particles, followed by Activated carbon filter for color and odor removal along with ultra-filtration. Treated water will be disinfected through ozone sterilize. Filtered water will be good enough for irrigation and flushing of toilets and urinals. This water will be further treated through a softener to reduce hardness to use in cooling tower.
- Additional treatment like Ozone Sterilization instead of UV and Ultra-filtration
- Total sludge generated from SBR will be stored in a sludge holding tank for further digestion. Diffused air will be supplied through aerators for digestion and to increase the consistency in sludge holding tank. Digested and thickened sludge will be pumped to filter press/ centrifuge further reduction of water. Polyelectrolyte will be added if necessary.



Filtrate from the filter press/ centrifuge will be pumped back to the equalization tank and dewatered sludge will be used as manure after drying.

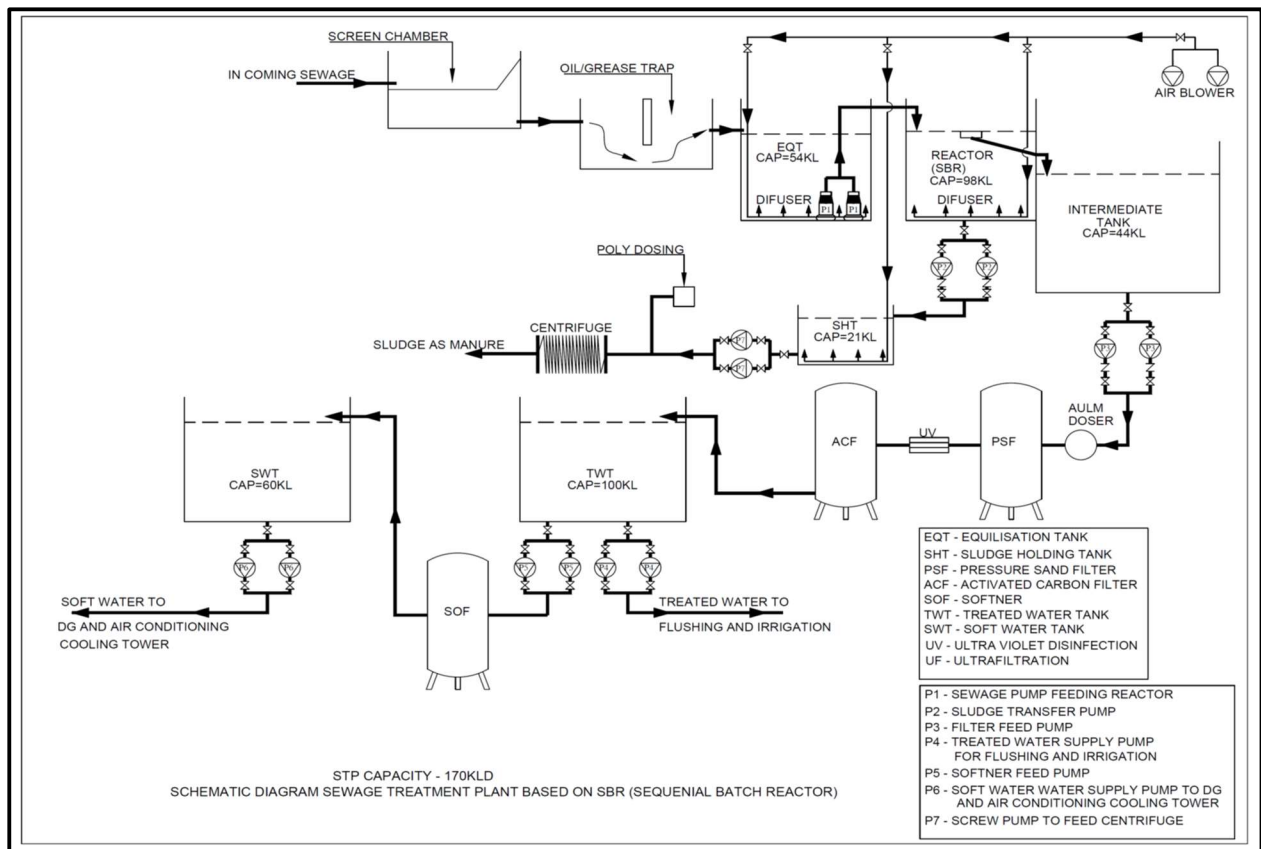

**\* Note: SCADA Automation will be used for said STP.**

**Figure-1.0: Working principle of SBR**

## Ozone Treatment

Ozone dosing will be done to disinfect treated effluent, which will oxidise the microbe completely in effluent as well as reduce the BOD between 5mg/ litre to 10 mg/ litre.

## **RAIN WATER HARVESTING**

The storm water disposal system for the premises shall be self-sufficient to avoid any collection/stagnation and flooding of water. The amount of storm water run-off depends upon many factors such as intensity and duration of precipitation, characteristics of the tributary area and the time required for such flow to reach the drains. The drains shall be located near the carriage way along either side of the roads. Taking the advantage of road camber, the rainfall run off from roads shall flow towards the drains. Storm water from various buildings shall be

connected to adjacent drain by a pipe through catch basins. Therefore, it has been calculated to provide 3 rainwater harvesting pits at selected locations which will catch the maximum run-off from the area. The pit design is given below:

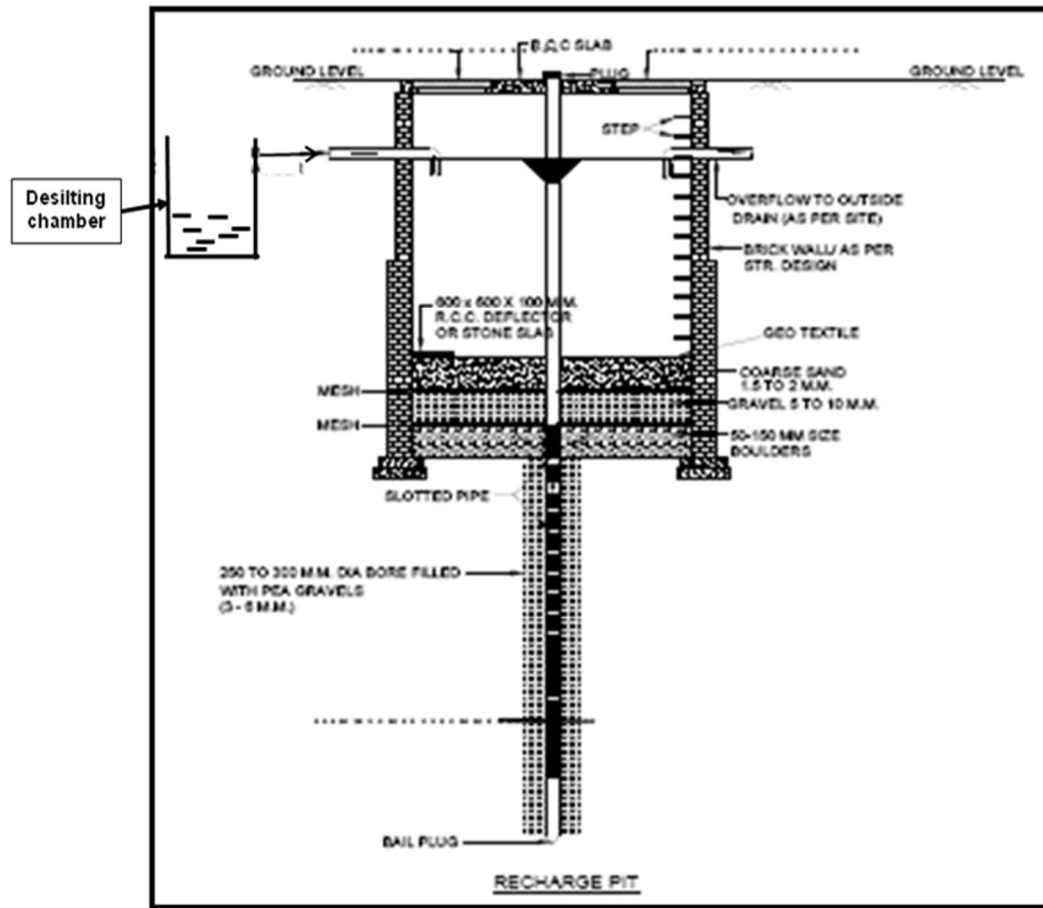

## SOLID WASTE GENERATION

Solid waste will be generated both during the construction as well as the operation phase. The solid waste expected to be generated during the construction phase will comprise of excavated materials, used bags, bricks, concrete, MS rods, tiles, wood etc. The following steps are proposed to be followed for the management of solid waste:

- Construction yards are proposed for storage of construction materials.
- The excavated material such as topsoil and stones will be stacked for reuse during later stages of construction
- Excavated top soil will be stored in temporary constructed soil bank and will be reused for landscaping of the group housing project.

- Remaining soil shall be utilized for refilling / road work / rising of site level at locations/ selling to outside agency for construction of roads etc.

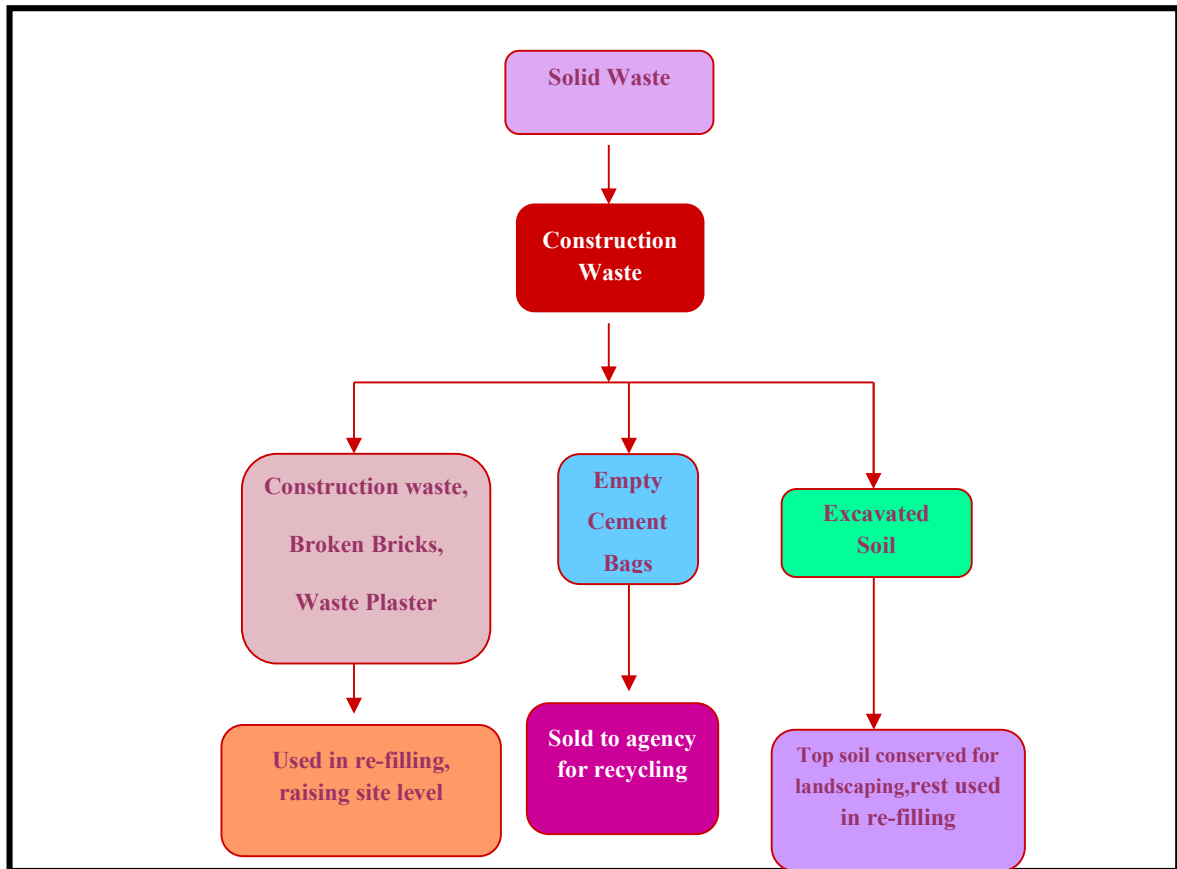

**Solid Waste Management Scheme (Construction Phase)**

Waste will consist of domestic as well as gardening waste during the operation phase. The solid waste generated from the complete project including the proposed development shall be mainly domestic waste and estimated quantity of the waste shall be approx. 0.180 MT per day (@ 0.2 kg per capita per day for fixed population and 0.1 kg per capita for the visitors. Various arrangements will be made at the site in accordance to Municipal Solid Wastes (Management and Handling) Rules, 2016 as discussed later on.

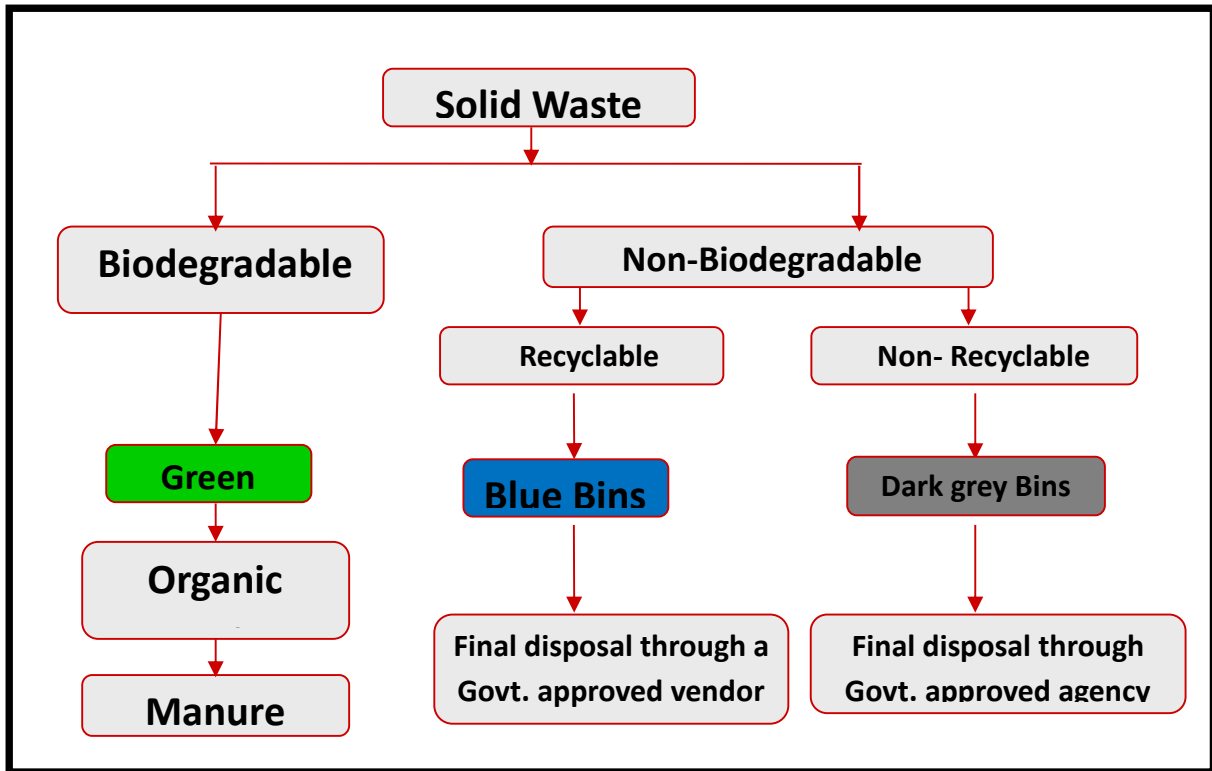

### Solid Waste Management Scheme (Operation Phase)

#### GREEN AREA

It is proposed to have 0.419 acres (1694.881 sq m or ~10% of total area) as green/landscape area (for Shelter belt, for Avenue plantation, for Landscape, herbs, shrubs, water bodies and climbers). Evergreen tall and ornamental trees like Belonix regia, Polvalthia longfolia, Veronia selowna, Cassia fistula, etc. will be planted inside the premises.

#### PROJECT COST

The anticipated total cost for the proposed project will be ~ Rs. 72.89 Crores. This includes land, construction, approvals, etc.

#### 4.0 CONCLUSION

The proposed project has been designed in a sustainable way to have the least impact on the environment. The project will have an overall positive impact in terms of job opportunities during the construction phase and organized commercial and infrastructure development during the operation phase. It will also enhance the overall aesthetics of the area.